

TILE STOVE INSERTS FROM BRUNNER



HKD 7

State: 2024-02-07



BRUNNER[®]
made in germany.

Dimension sheets - HKD 7

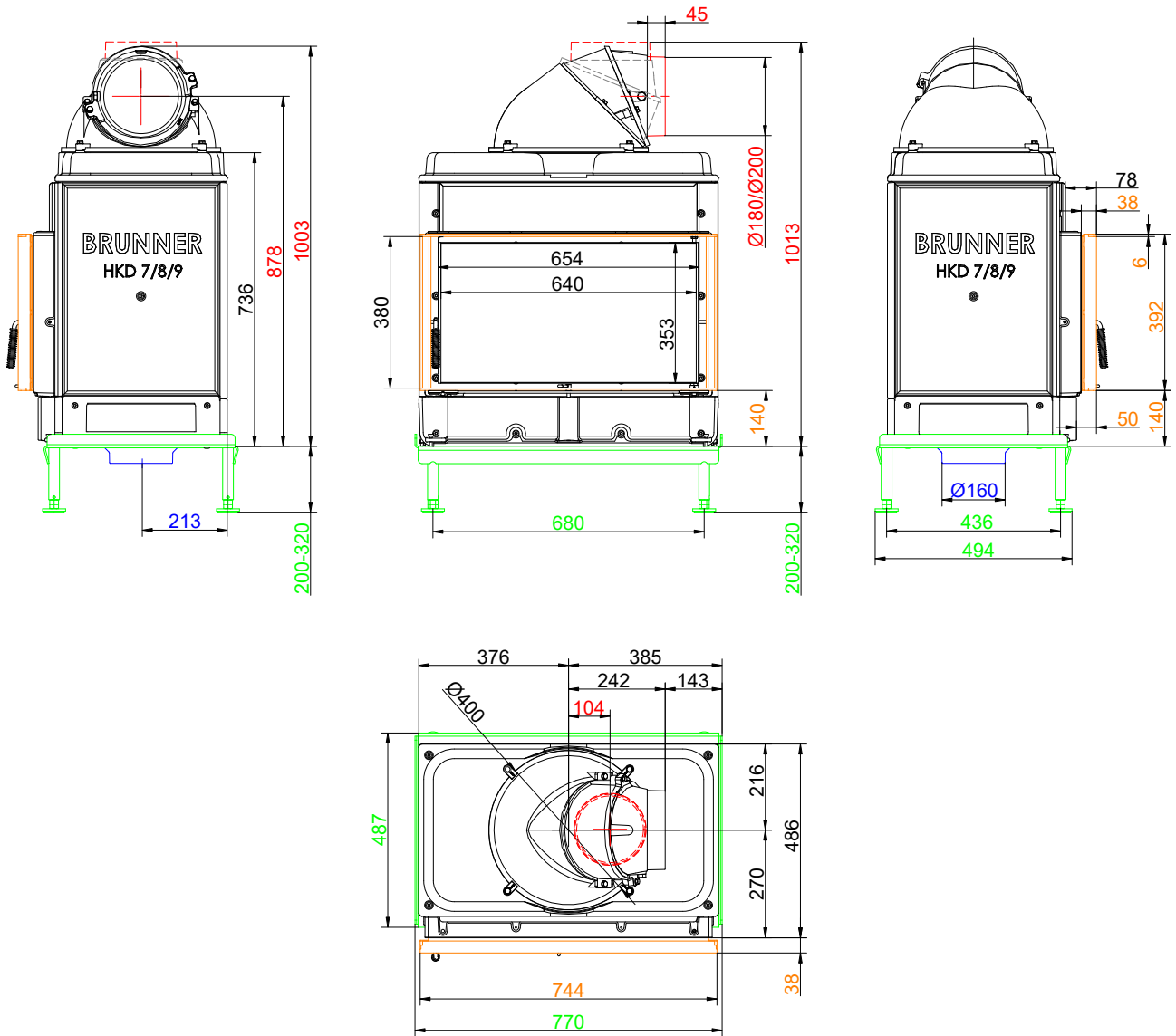

... mounting frame and cast iron dome

Dimension sheets - HKD 7

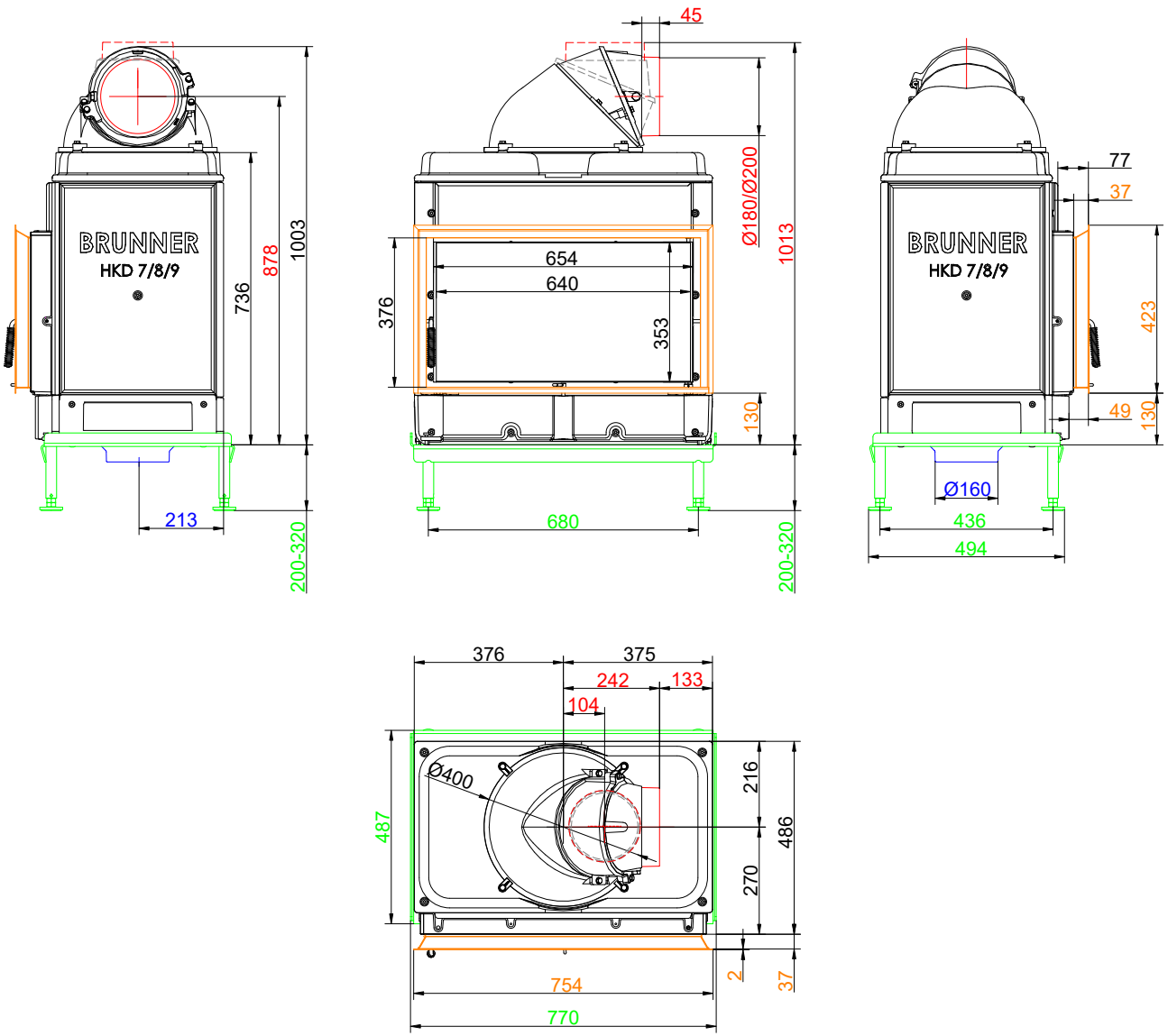

... door frame and cast iron dome

Dimension sheets - HKD 7

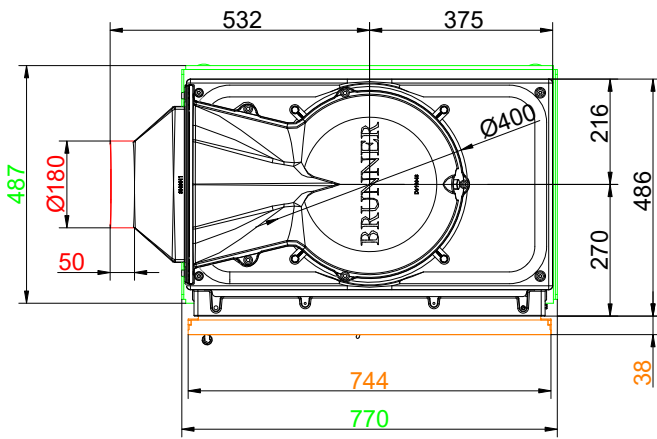
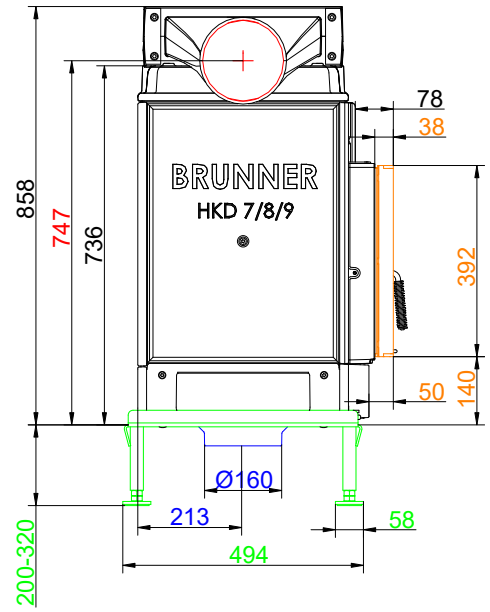
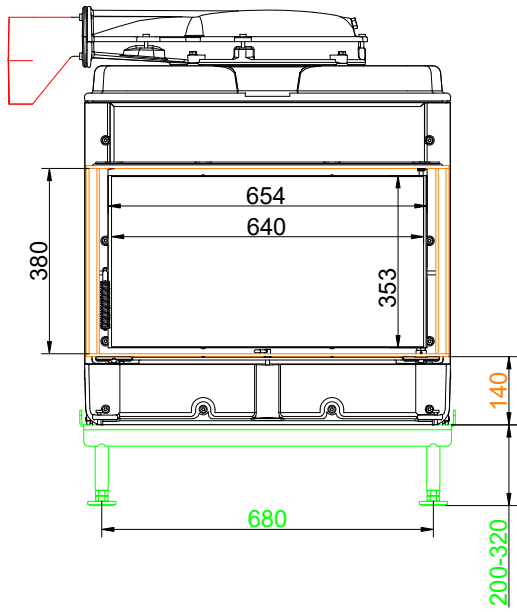

... mounting frame and cast iron dome low

Dimension sheets - HKD 7

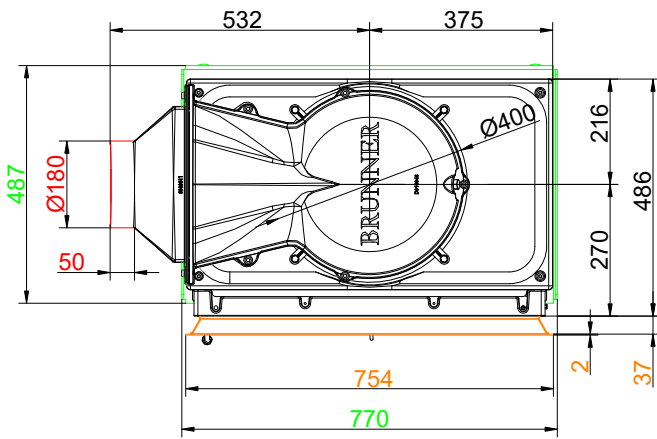
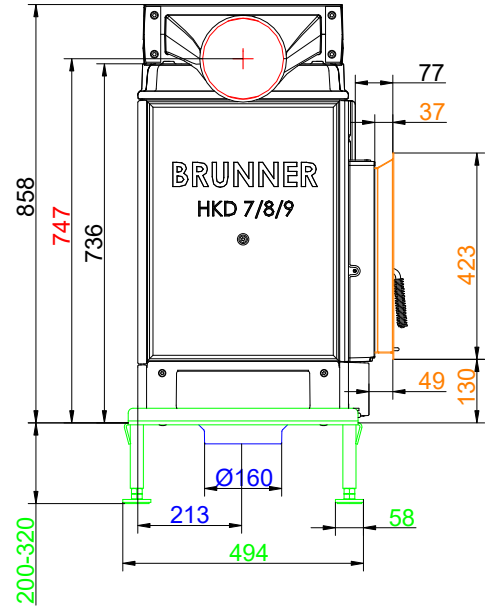
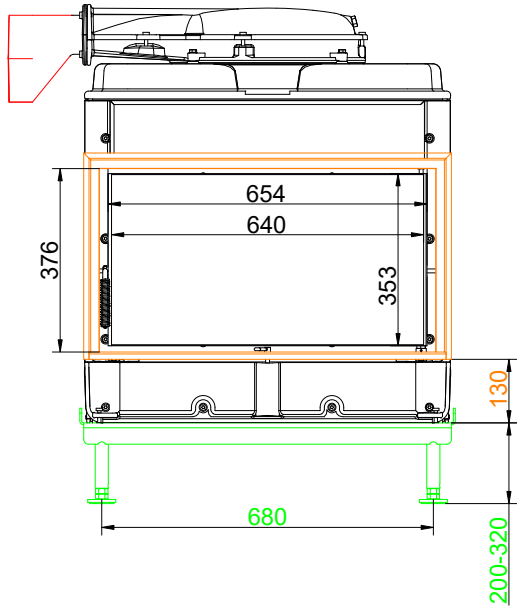

... door frame and cast iron dome low

Dimension sheets - HKD 7

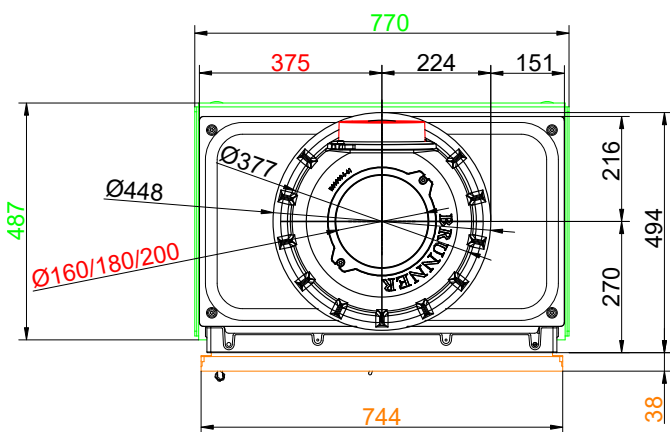
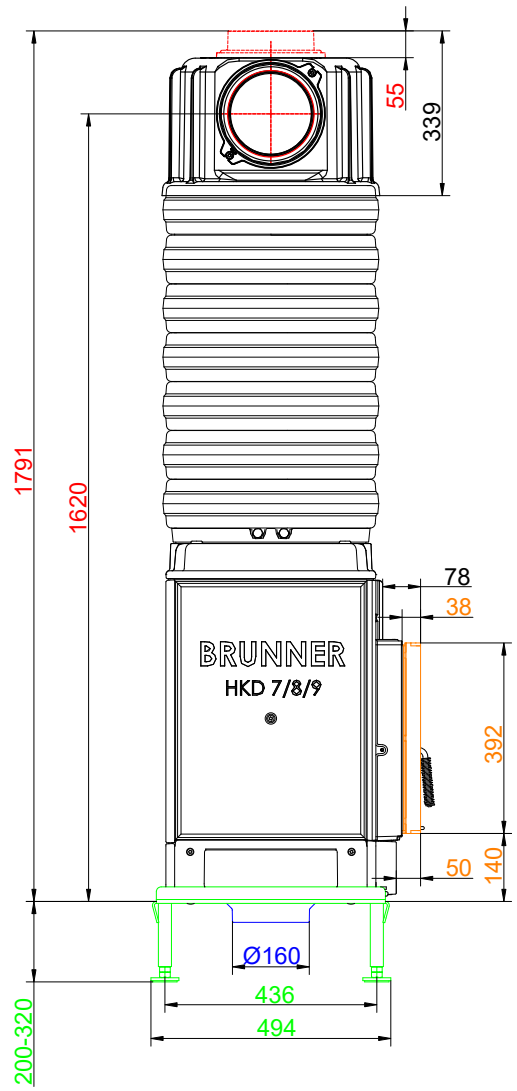
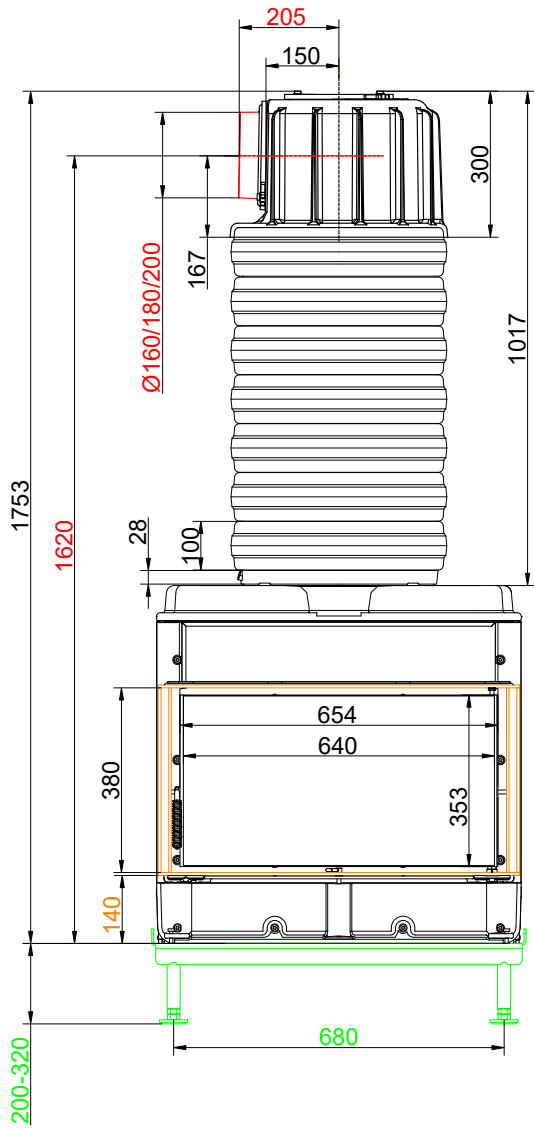

... mounting frame and MAS

Dimension sheets - HKD 7

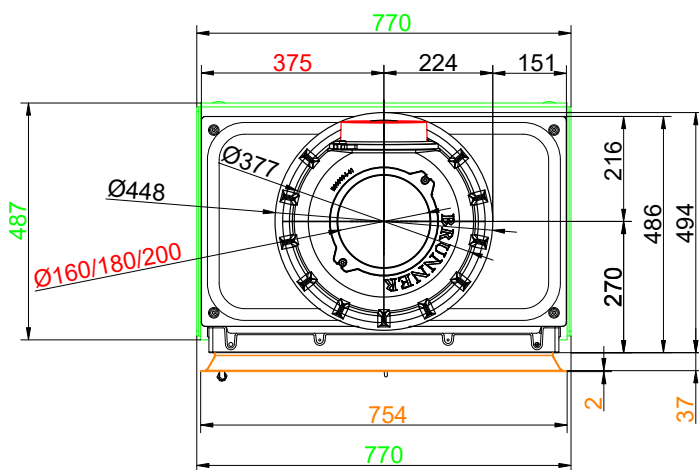
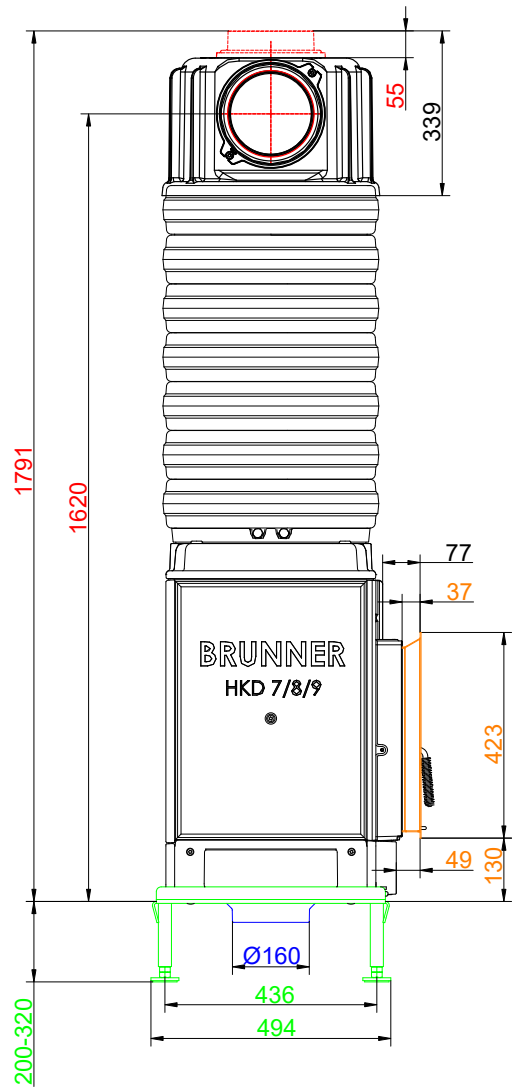
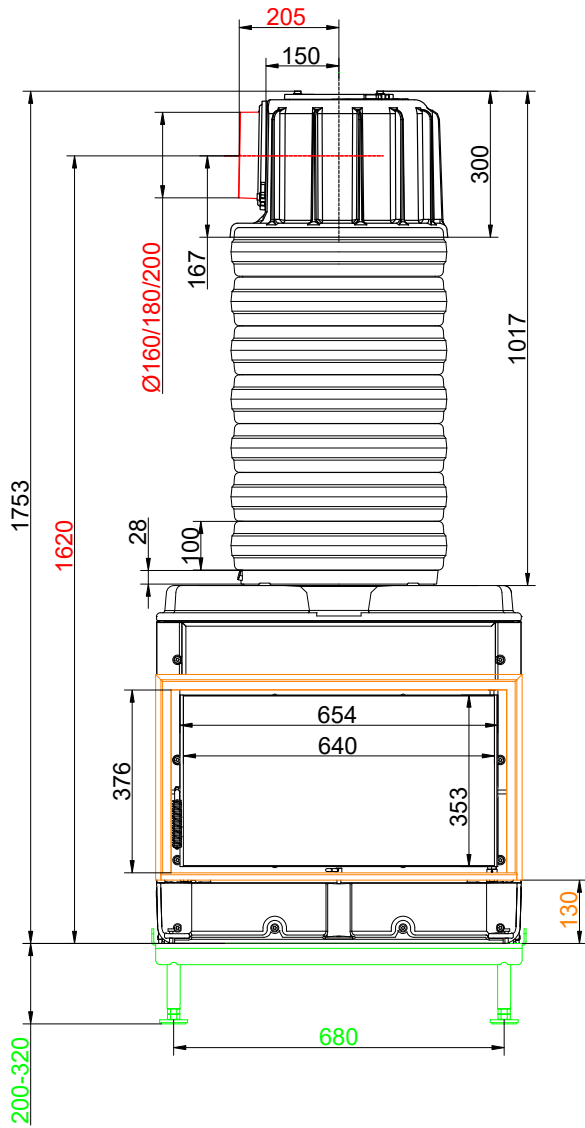

... door frame and MAS

Dimension sheets - HKD 7

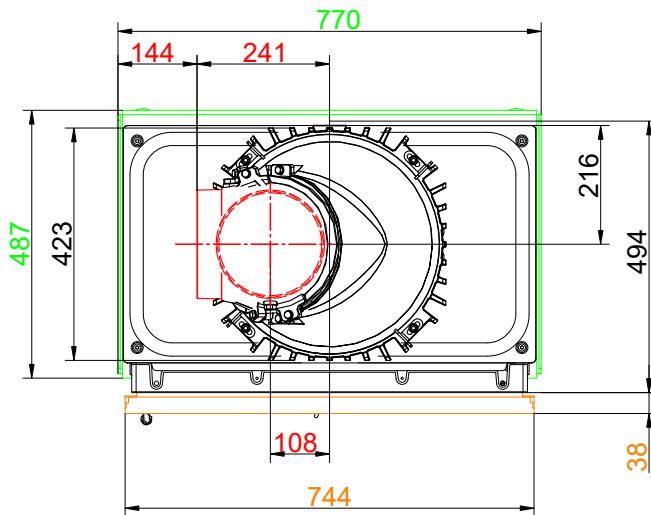
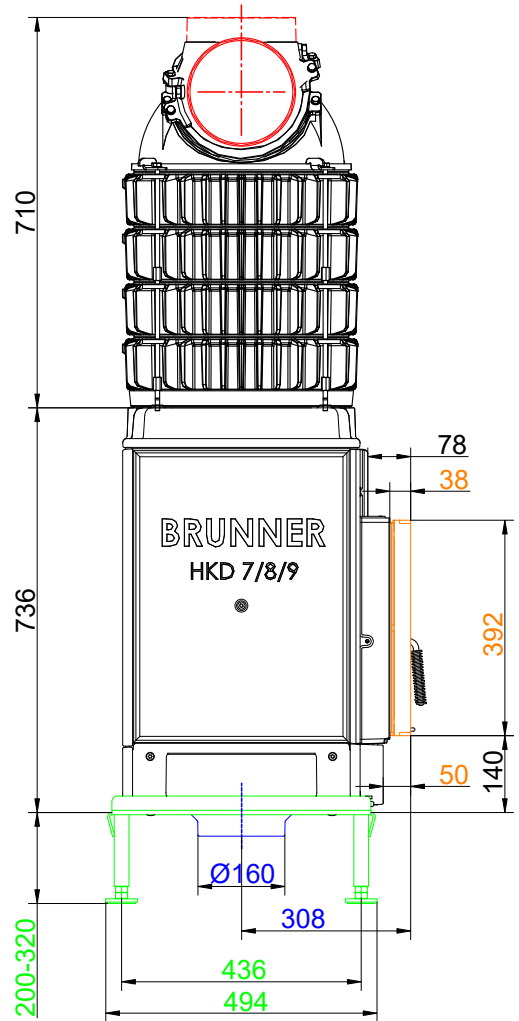
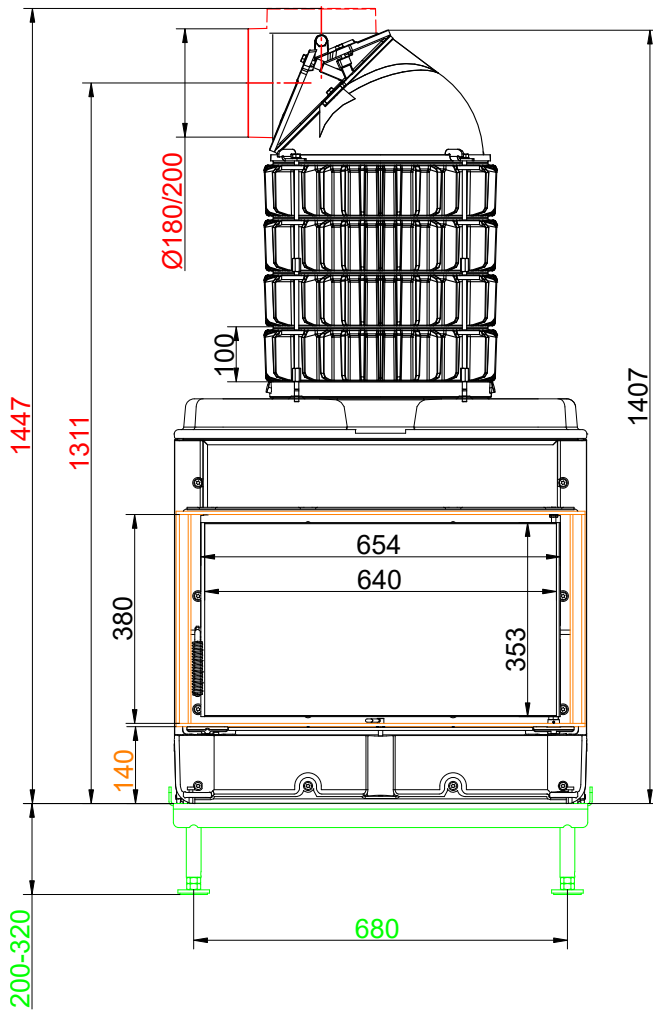

... Mounting frame and cast iron heat exchanger rings + dome

Dimension sheets - HKD 7

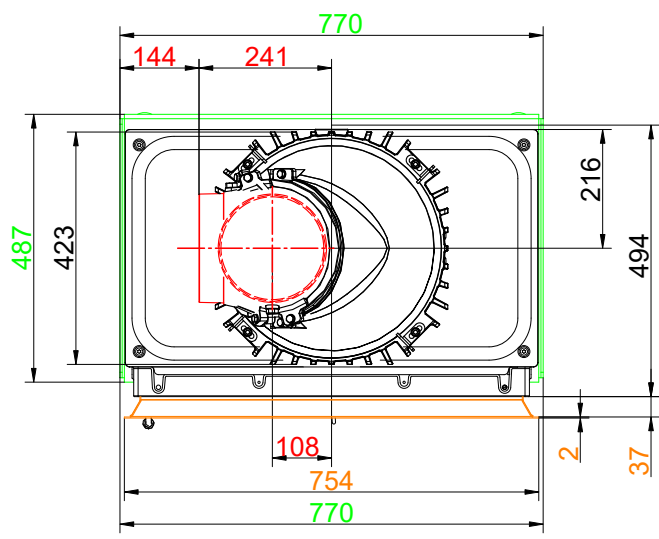
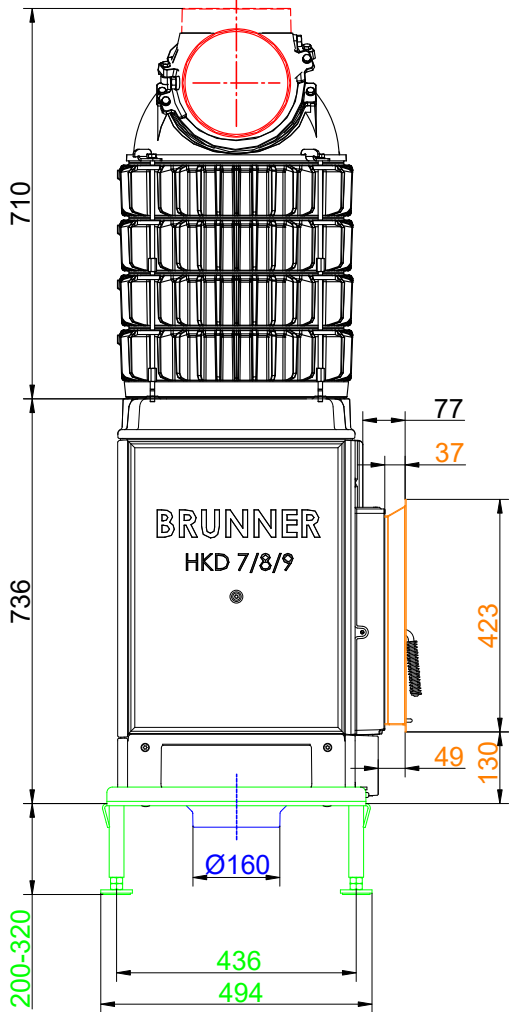
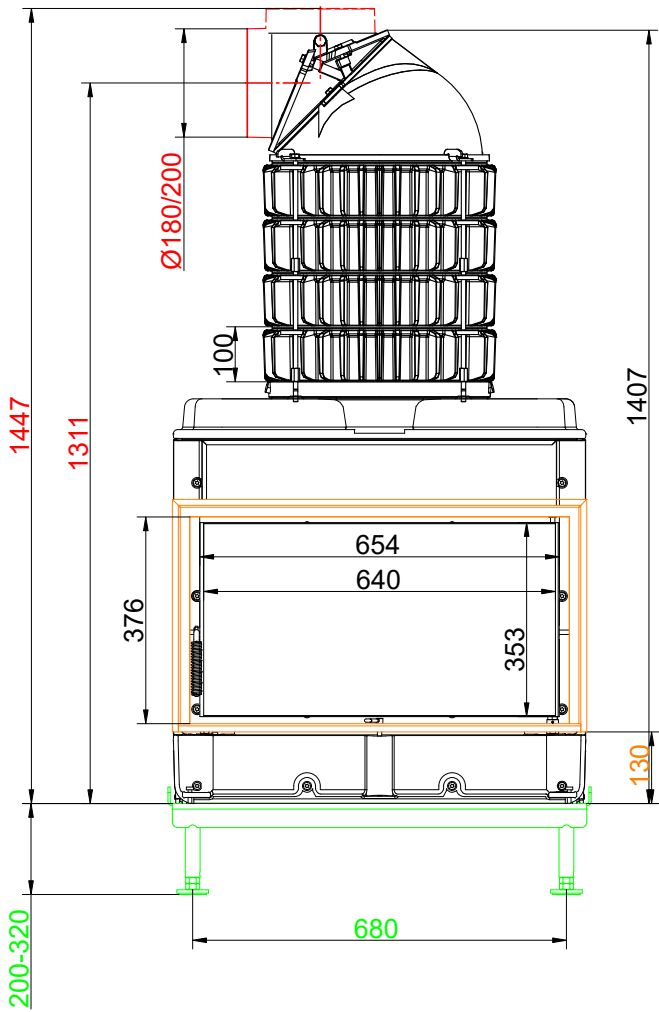

... Door frame and cast iron heat exchanger rings + dome

Dimension sheets - HKD 7

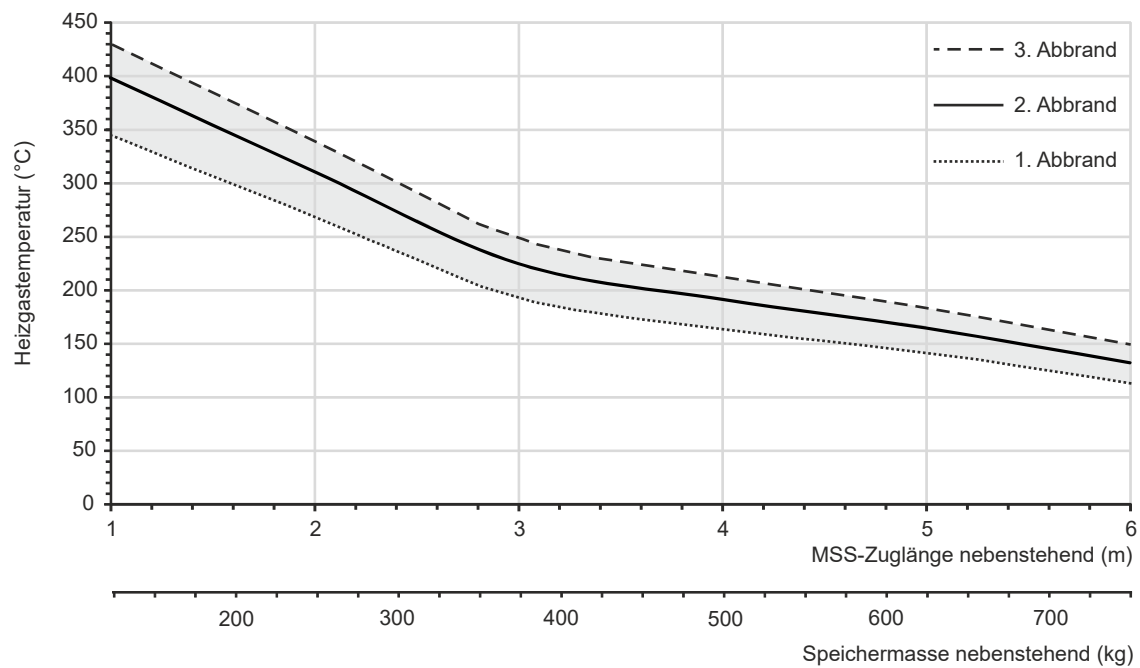

Design characteristics for adjacent storage mass

We suggest for CAD planning Palette CAD. Permanent updated drawings: www.brunner.de

Frames/ flue gas outlet connection/ combustion air supply connection/ front variants/ support bearing are marked in color.

Planning and installation - HKD 7

Tested according to		EN 13229 W	EN 13229 WA
Values measured at		Rated power ¹⁾	Storage operation ²⁾
Suitable for all construction types according to rules		OK	OK
Data for functional demonstration			
Rated heat power	kW	9	-
Fire wood volume	kg/h	2.7	5.5
Combustion performance	kW	10.5	22.0
Flue gas mass flow	g/s	8.5	20.0
Outlet temperature (before reheating surface)	°C	460	540
Flue gas temperature after:			
1 x adjoining cast iron radiator (GNF 8/10)	°C	180	215
4 x cast iron heat exchanger rings + dome	°C	220	260
7 x accumulation rings incl. MAS casted cover ³⁾	°C	220	-
4,9 m ceramic accumulator ⁴⁾	°C	-	180
3,4 m accumulation stones (MSS) ⁴⁾	°C	-	190
Necessary supply pressure	Pa	12	15
Combustion air consumption	m ³ /h	25	48
Flue gas pipe connection Ø	mm	180 / 200	180 / 200
Combustion air connection Ø	mm	125 / 160	125 / 160
Heating gas temperature (before the hood/dome variant)			
cast iron dome	°C	460	540
Heat distribution			
Insert / reheating surface	%	40 / 40	40 / 40
Glass pane (single / double)	%	- / 20	- / 20
Cross-section of gratings ⁵⁾			
exhaust warm air	cm ²	700 / 300 / 500	700 / 300 / 500
Recirculation air	cm ²	700 / 300 / 500	700 / 300 / 500
Minimal distances of the fireplace			
to cladding, insulation layer	cm	8	8
to mounting floor	cm	15	15
Thermal insulation without / with air gratings ⁶⁾			
Mounting wall	cm	12 / 10	12 / 10
Floor	cm	0	0
Ceiling	cm	22 / 16	22 / 16
Brick lining for combustible wall	cm	10	10
Weight			
Fireplace / combustion chamber	kg	248 / 66	
Meets requirement/limit values for:			
Germany/ Austria / Switzerland / Norway		1.BImSchV (Stufe 2) / 15a BvG (2015) / LRV / -	

- 1) Indications to "Rated power" determined with metallic reheating surface
- 2) Indications to "Storage operation" for the manual execution of the reheating surface (guide values).
- 3) Damper flap recommended
- 4) Approximate value. Determination according to design characteristics for adjacent storage mass or proof of function provided by calculation
- 5) for fireplace/heating inserts / flue gas pipe / metallic reheating surface/if the specified nominal heat output is required as the heating output.
- 6) Fire safety: values determined with air cross-sections evaluated by safety testing; stove cladding is heat emitting. Insulation material data with reference insulation material (mineral wool according to AGI Q 132).