

TILE STOVE INSERTS FROM BRUNNER



WF 50

State: 2023-08-30



BRUNNER[®]
made in germany.

Dimension sheets - WF 50

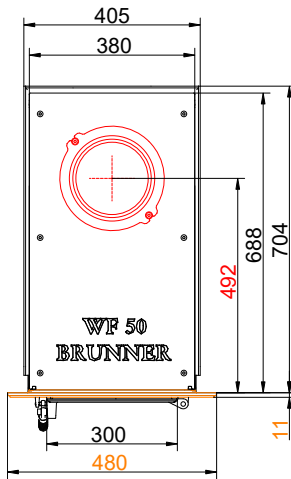
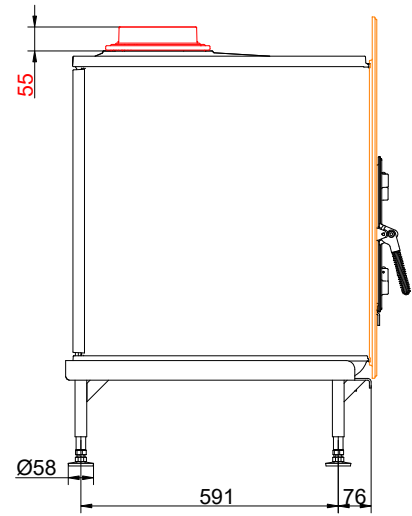
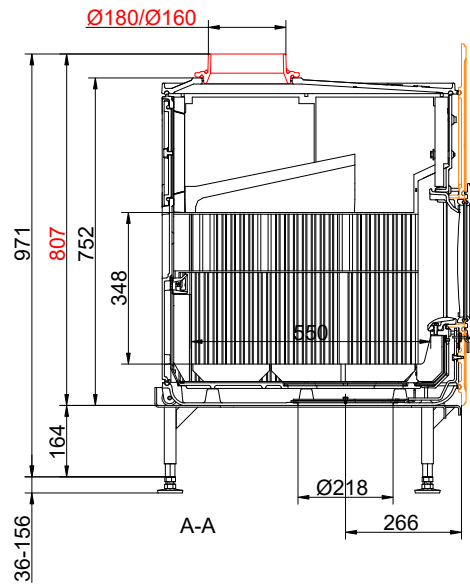
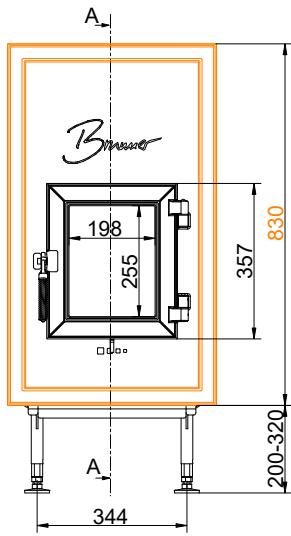

... cast iron front plate 830 X 480

Dimension sheets - WF 50

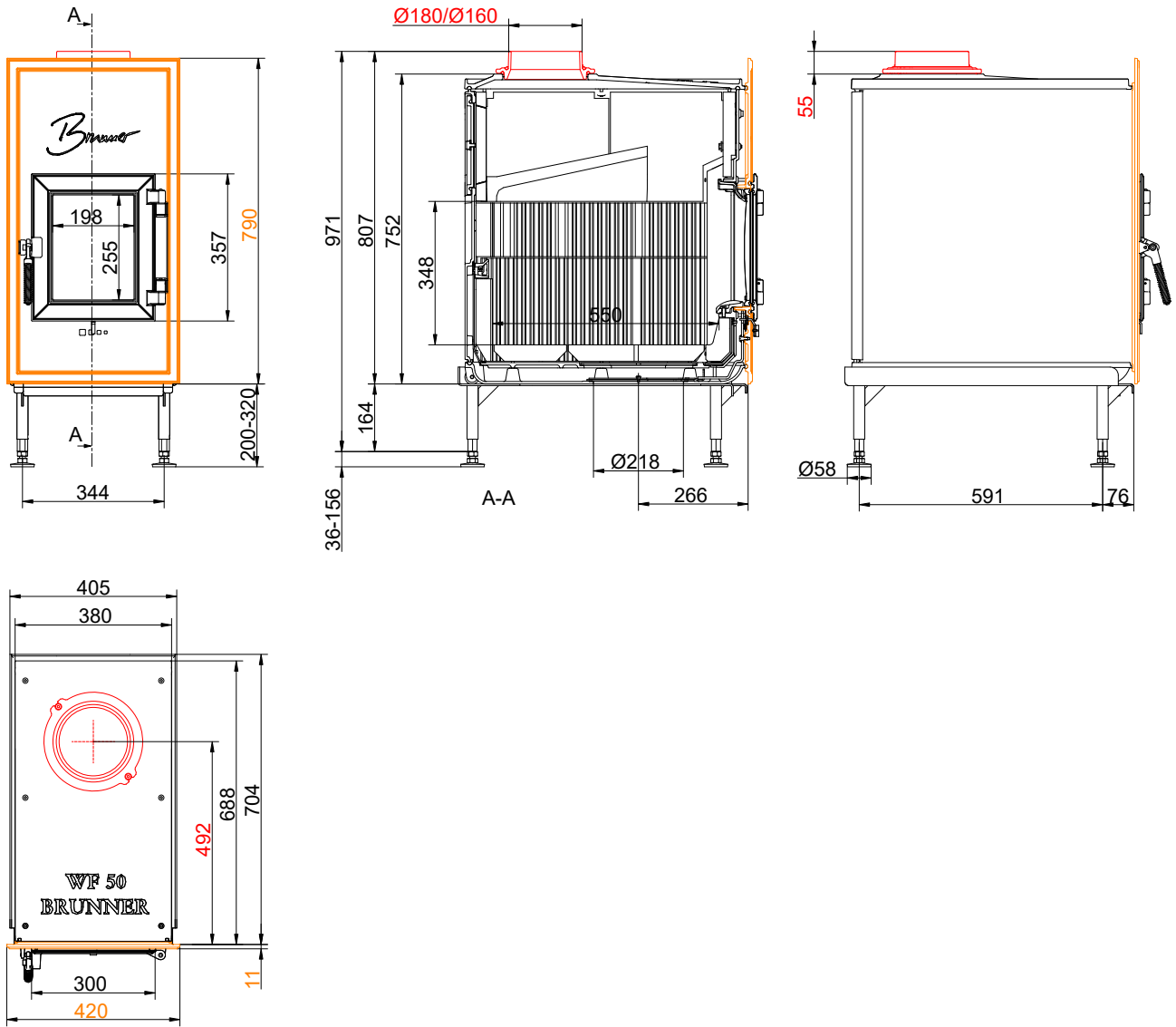

... cast iron front plate 790 x 420

Dimension sheets - WF 50

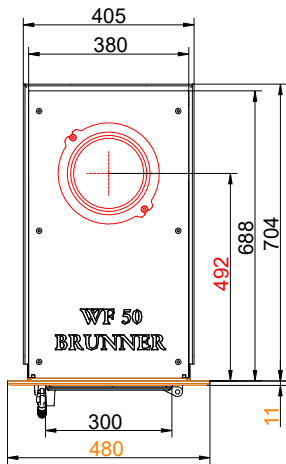
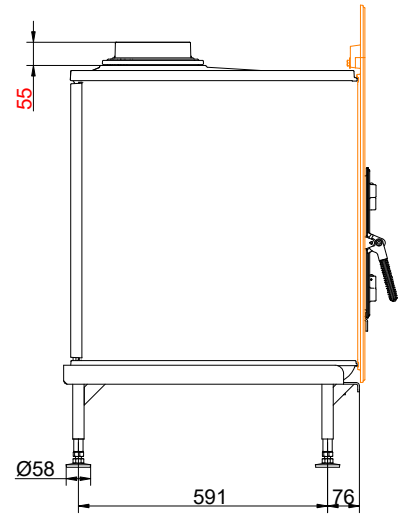
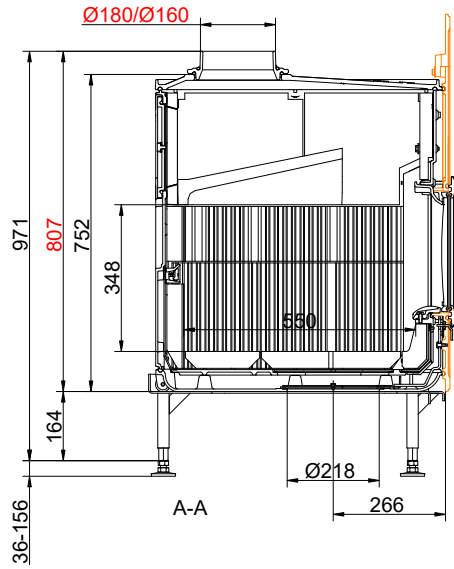
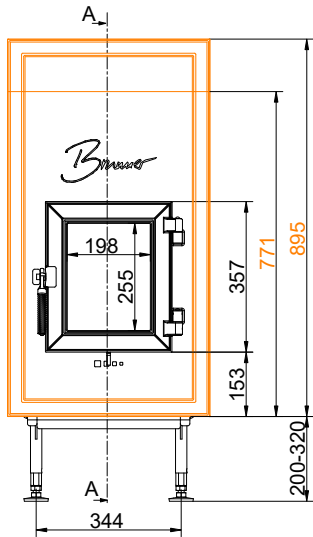

... cast iron front plate 895 x 480

Dimension sheets - WF 50

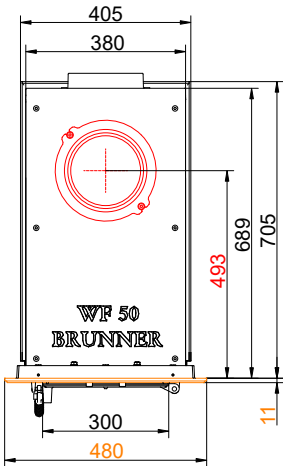
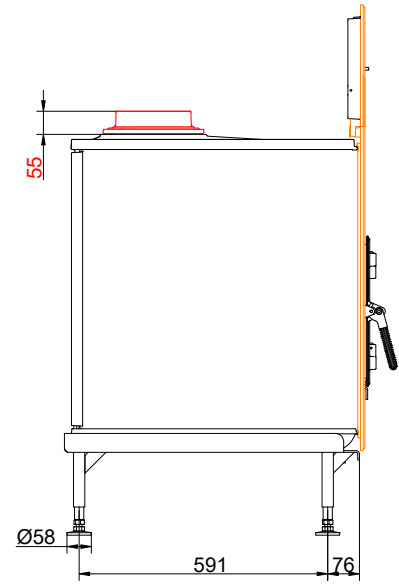
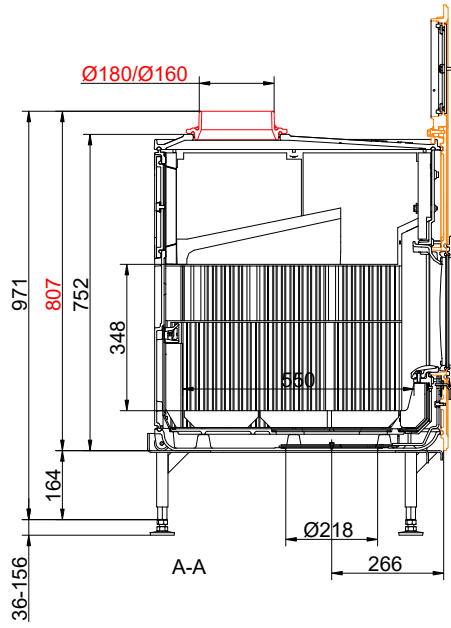
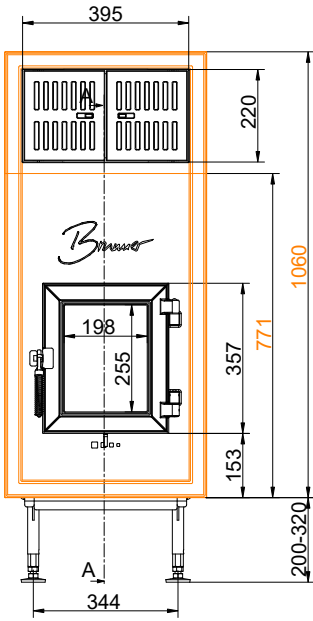

... cast iron front plate 1060 x 480

Dimension sheets - WF 50

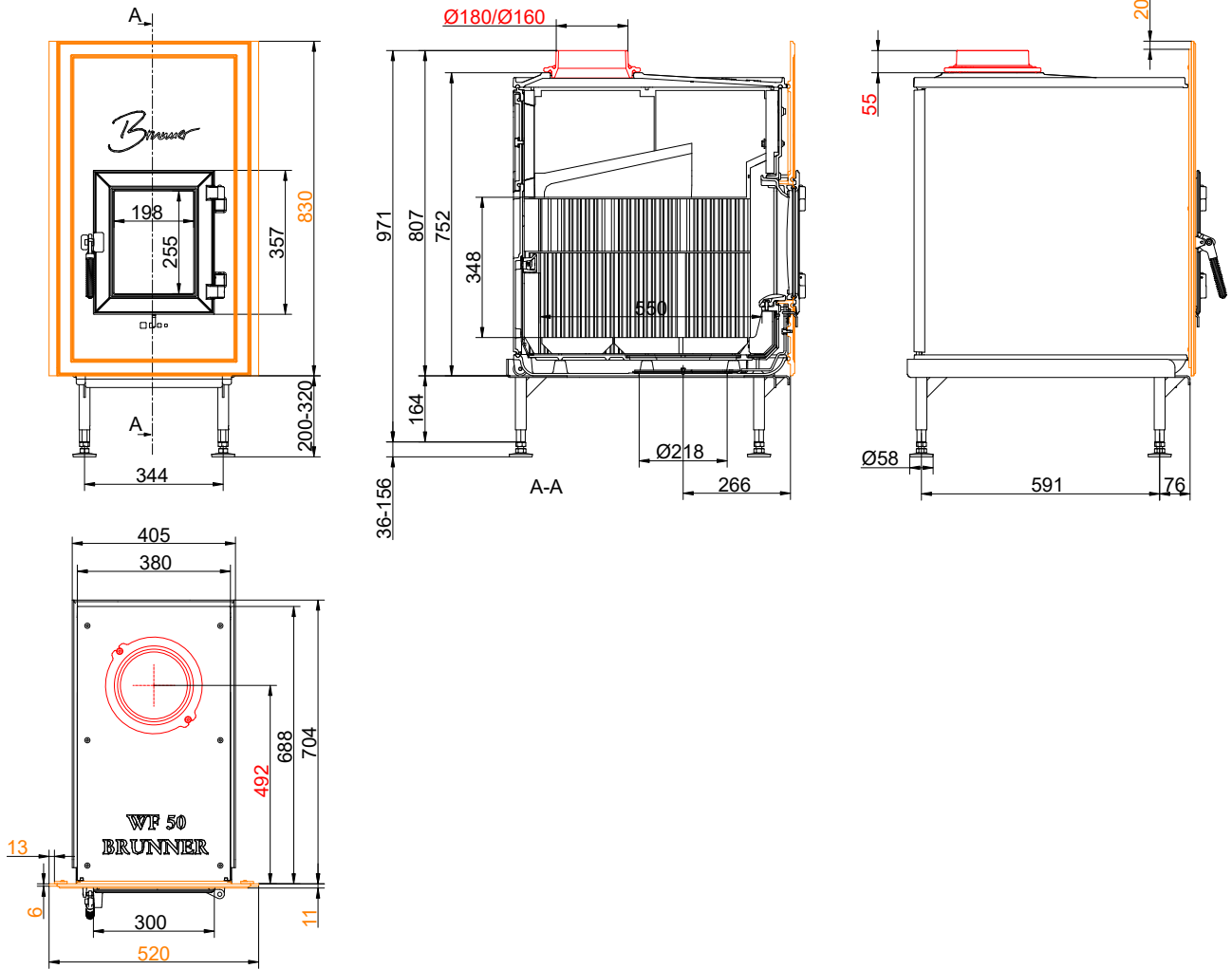

... cast iron front plate 830 X 520

Dimension sheets - WF 50

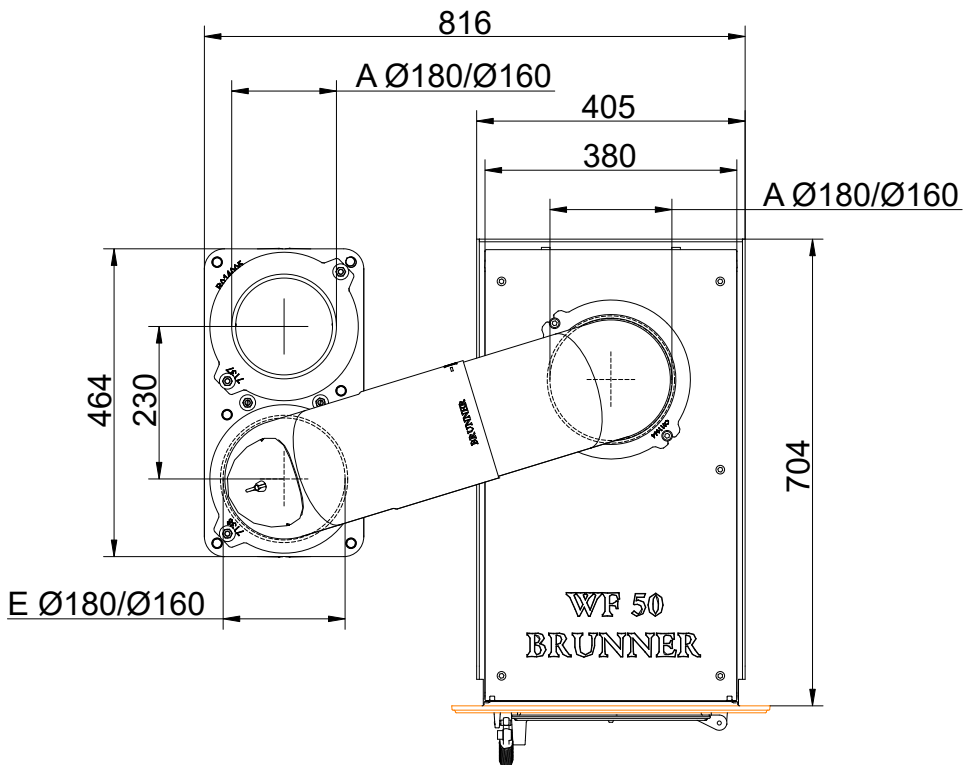
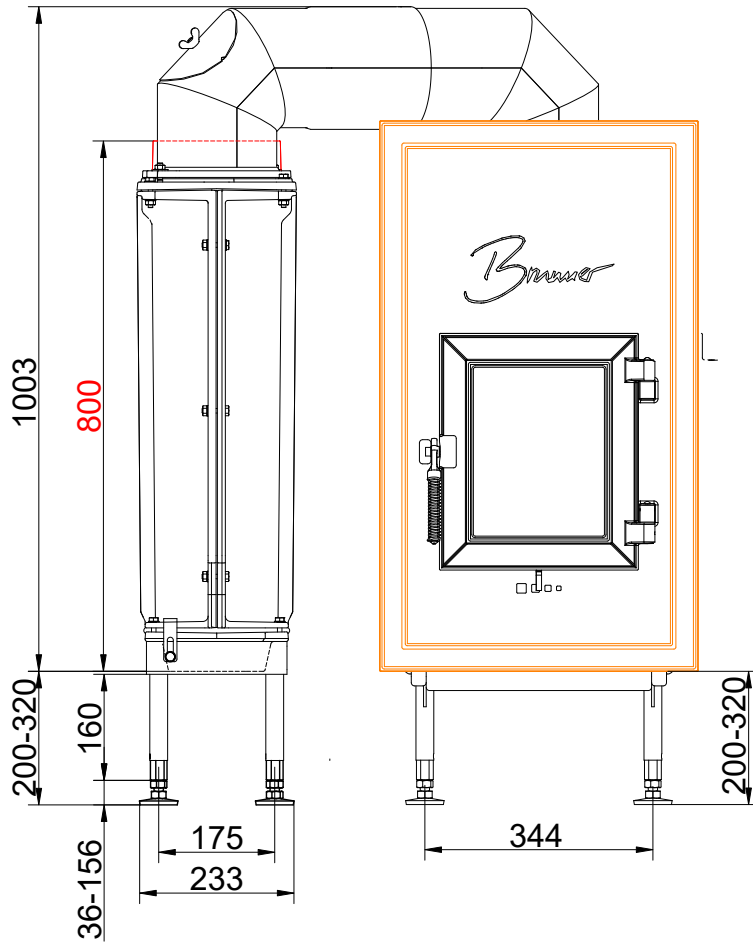

... with GNF 8 at the side

Dimension sheets - WF 50

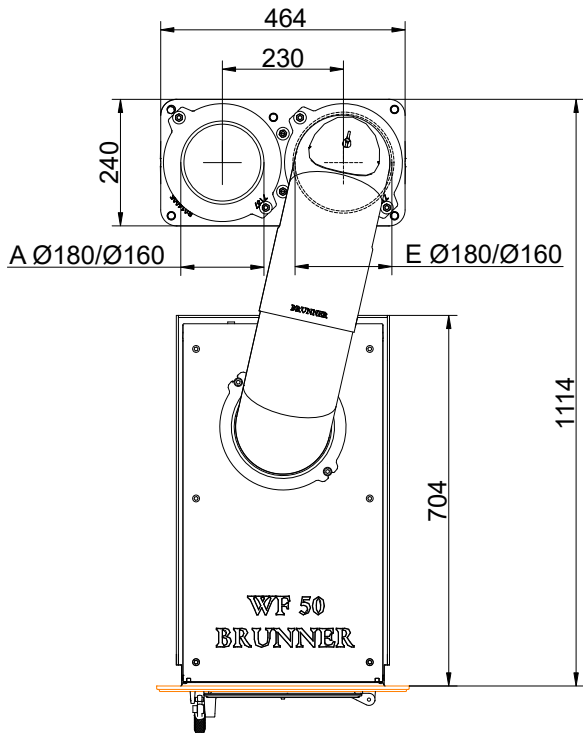
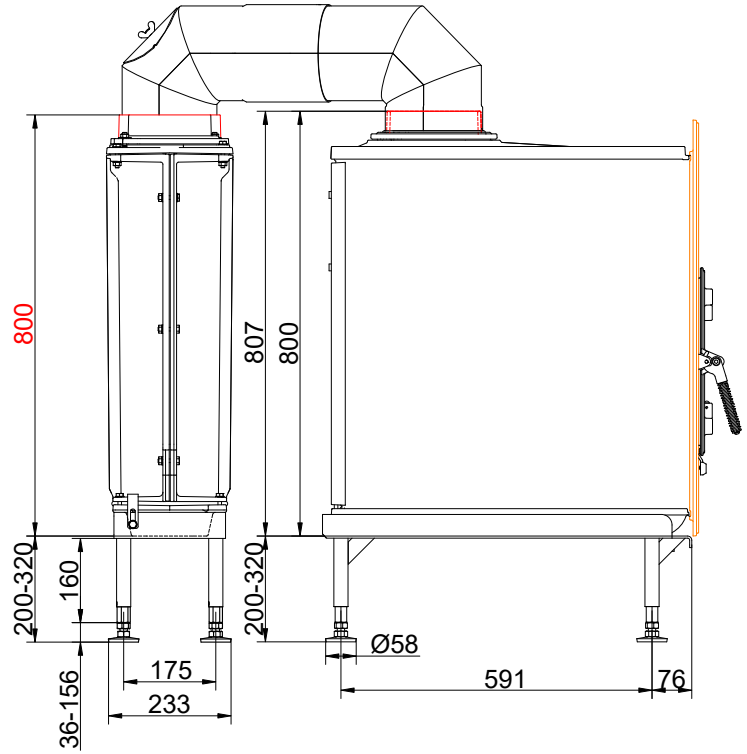
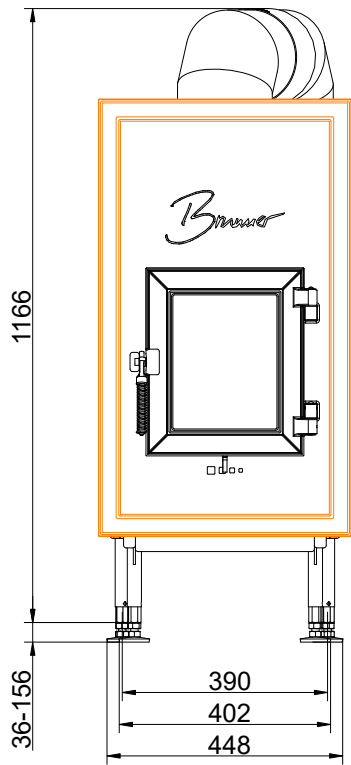

... with GNF 8 behind

Dimension sheets - WF 50

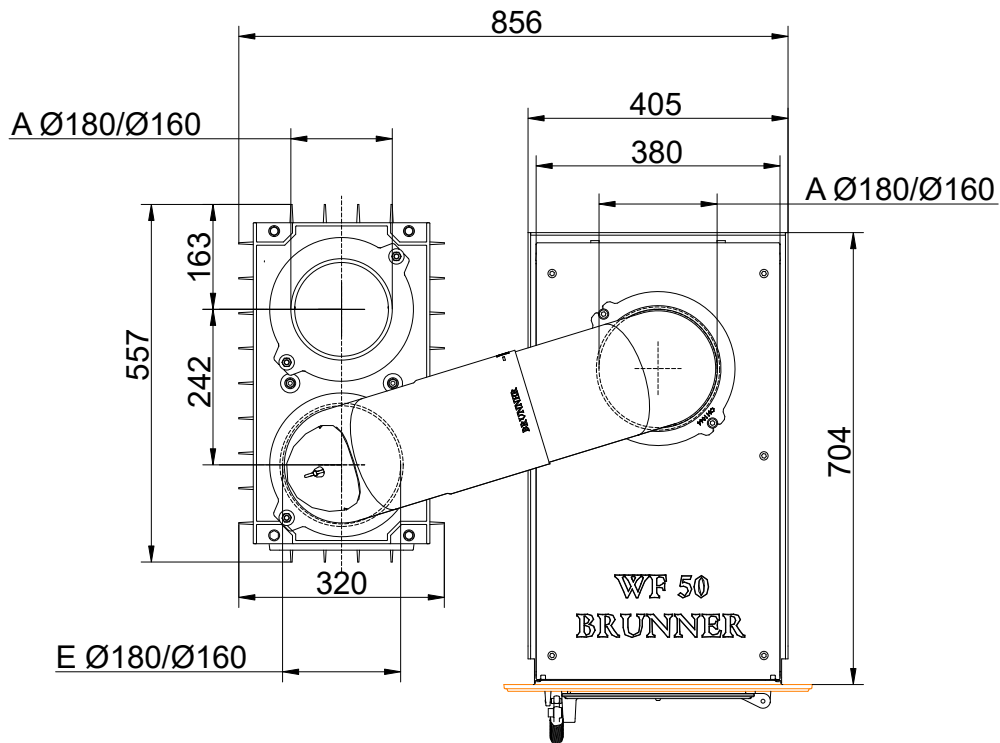
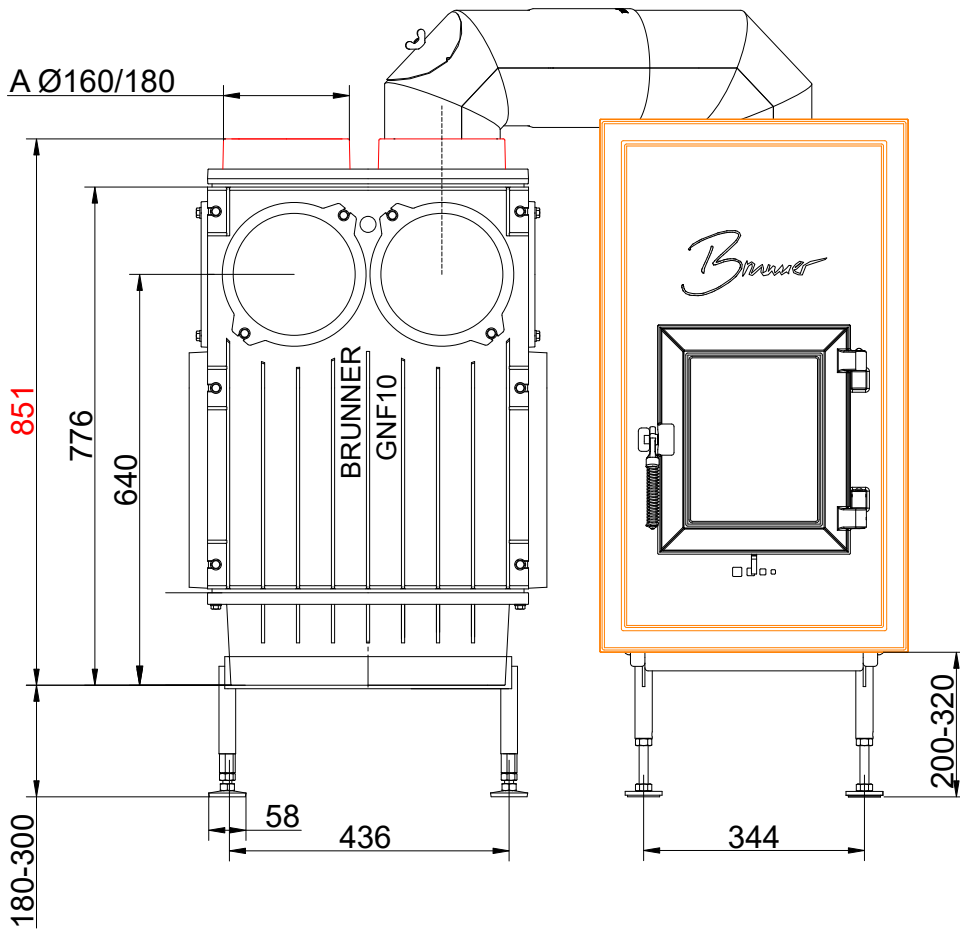

... with GNF 10 at the side

Dimension sheets - WF 50

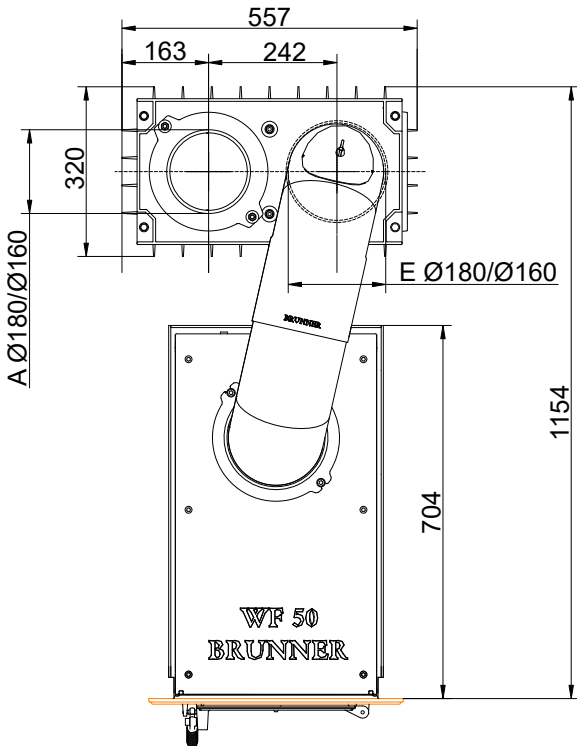
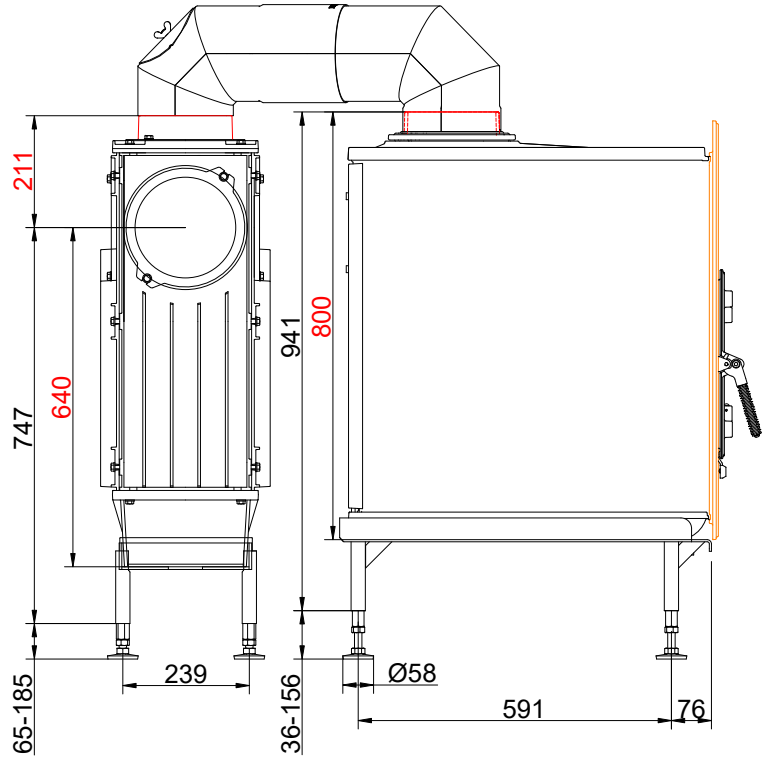
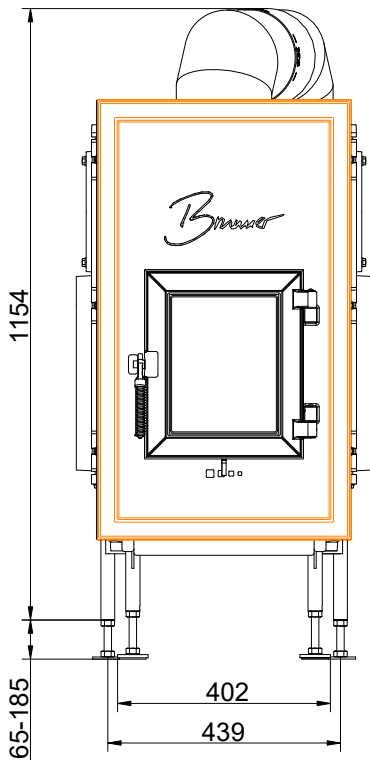

... with GNF 10 behind

Dimension sheets - WF 50

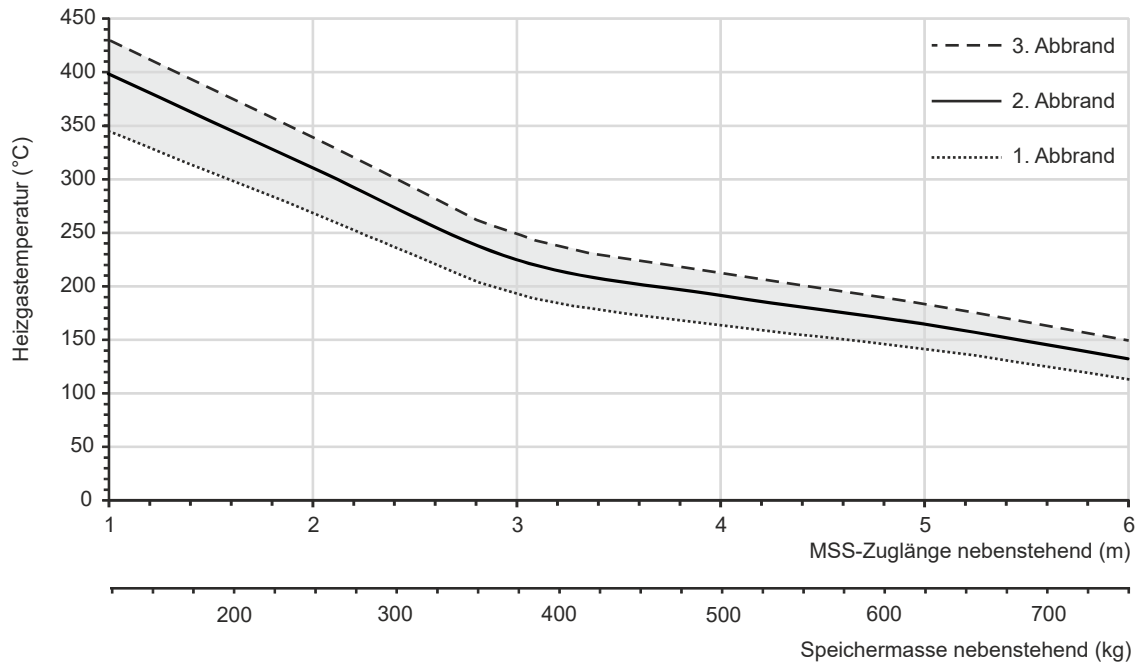

Design characteristics for adjacent storage mass

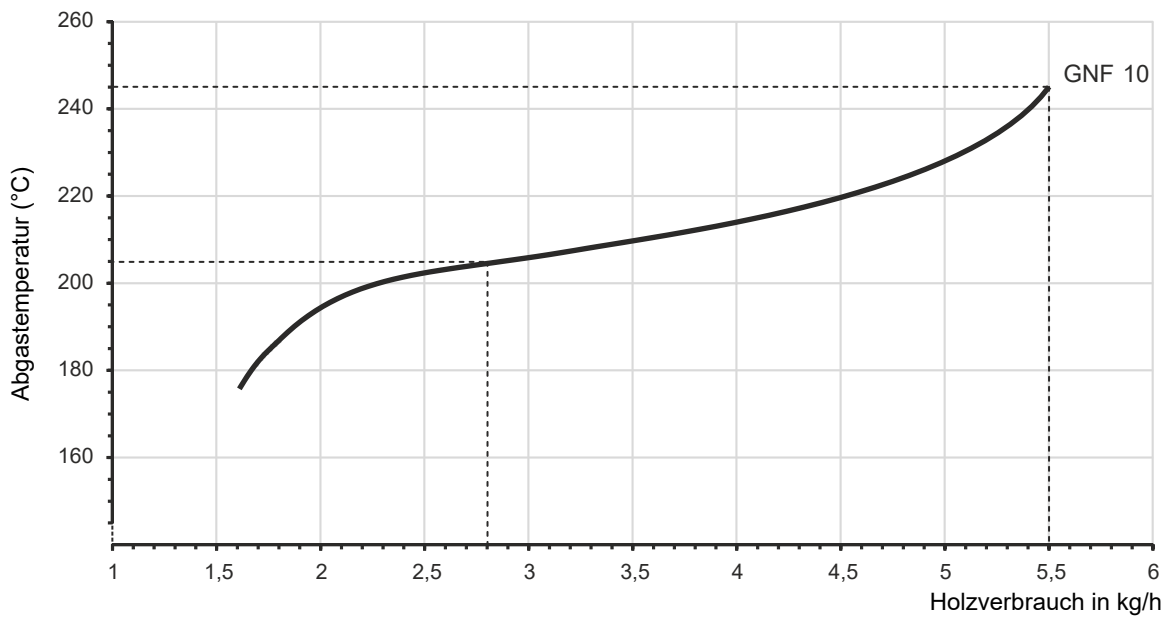

... Auslegungsdiagramm mit metallischer Nachheizfläche

Dimension sheets - WF 50

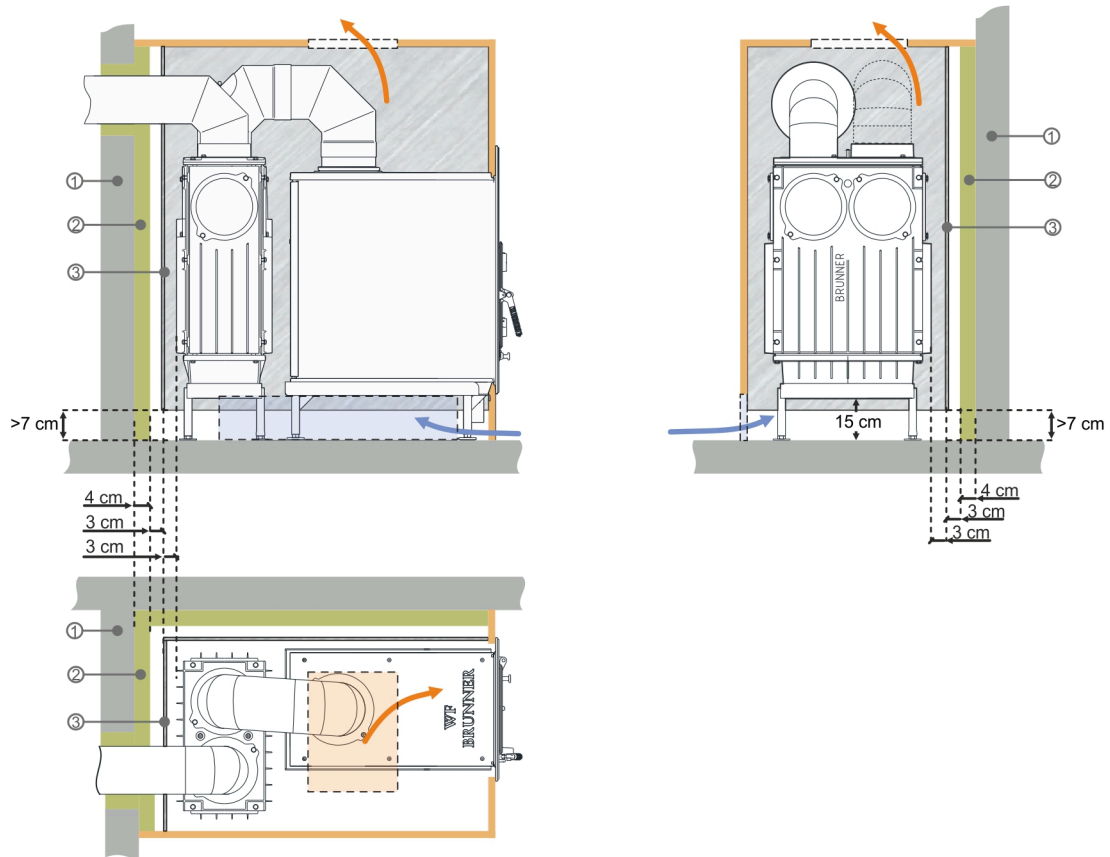

Alternative Wärmedämmung mit Hitzeschutzblech^{x)} vor Dämmschicht ^{xx)}.
1 Anbauwand (nicht brennbar), 2 Promasil 950KS, 3 Hitzeschutzblech feuerverzinkt (nicht schwarz).

^{x)} Hitzeschutzblech (kein schwarzes Blech!) wird bauseits über Abstandhalter zur Dämmschicht befestigt-

^{xx)} Werte ermittelt mit prüftechnisch erfassten Luftquerschnitten; Ofenhülle wärmeabgebend ausgeführt.

We suggest for CAD planning Palette CAD. Permanent updated drawings: www.brunner.de
 Frames/ flue gas outlet connection/ combustion air supply connection/ front variants/ support bearing are marked in color.

Planning and installation - WF 50

Tested according to		EN 13229 W	EN 13229 WA
Values measured at		Rated power ¹⁾	Storage operation ²⁾
Suitable for all construction types according to rules		OK	OK
Data for functional demonstration			
Rated heat power	kW	9	18
Fire wood volume	kg/h	2.8	5.5
Combustion performance	kW	10.5	22
Flue gas mass flow	g/s	10.1	16.2
Outlet temperature (before reheating surface)	°C	433	580
Flue gas temperature after:			
1 x adjoining cast iron radiator (GNF 10)	°C	205	245
4,9 m ceramic accumulator ³⁾	°C	-	180
3,4 m accumulation stones (MSS) ³⁾	°C	-	225
Necessary supply pressure	Pa	15	15
Combustion air consumption	m ³ /h	25	45
Combustion air connection Ø	mm	125	125
Heating gas temperature (before the hood/dome variant)			
insert flue outlet nozzle	°C	445	560
Heat distribution			
Insert / reheating surface	%	50 / 40	50 / 40
Glass pane (single / double)	%	10 / -	10 / -
Cross-section of gratings ⁴⁾			
Convection air	cm ²	700 / 200 / 500	700 / 200 / 500
Supply air	cm ²	700 / 200 / 500	700 / 200 / 500
Minimal distances of the fireplace			
to cladding, insulation layer	cm	8	8
to mounting floor	cm	15	15
Thermal insulation without / with air gratings ⁵⁾			
Mounting wall	cm	12 / 10	12 / 10
Floor	cm	0	0
Ceiling	cm	22 / 17	22 / 17
Brick lining for combustible wall	cm	10	10
Weight			
Fireplace / combustion chamber	kg	171 / 75 / -	
Meets requirement/limit values for:			
Germany/ Austria / Switzerland / Norway		1.BImSchV (Stufe 2) / 15a BvG (2015) / LRV / -	

- 1) Indications to "Rated power" determined with metallic reheater (gas slot 15 cm²) and double bends
- 2) Information on storage mode (WA) for operation with increased fuel quantity as well as for the manual execution of the reheating surface (reference value for the specialist company)
- 3) Approximate value. Determination according to design characteristics for adjacent storage mass or proof of function provided by calculation
- 4) for fireplace inserts / flue gas pipe / metallic reheating surface
- 5) Values determined with air cross-sections evaluated by testing; stove cladding is heat emitting.