

TILE STOVE INSERTS FROM BRUNNER



WF_R 25

State: 2023-08-30



BRUNNER[®]
made in germany.

Dimension sheets - WF_R 25

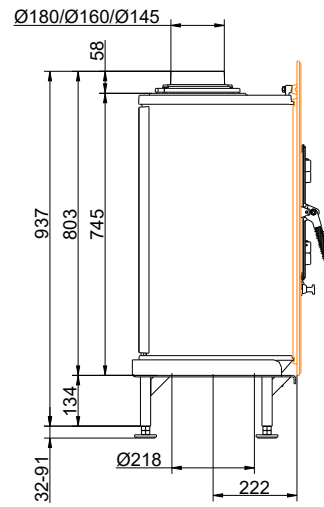
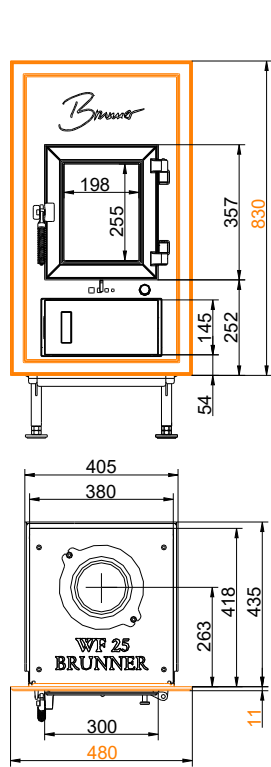

... cast iron front plate 830 X 480

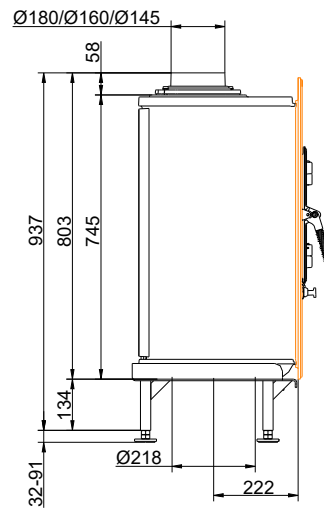
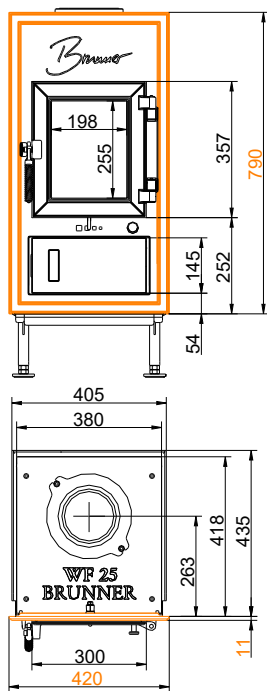

... cast iron front plate 790 x 420

Dimension sheets - WF_R 25

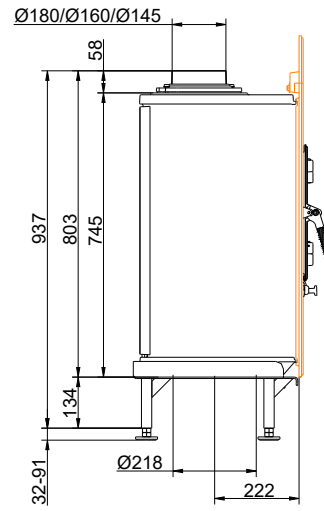
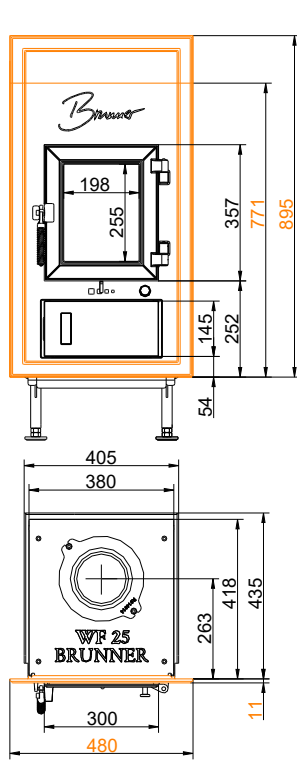

... cast iron front plate 895 x 480

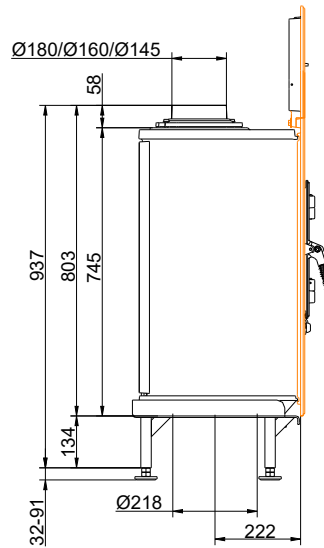
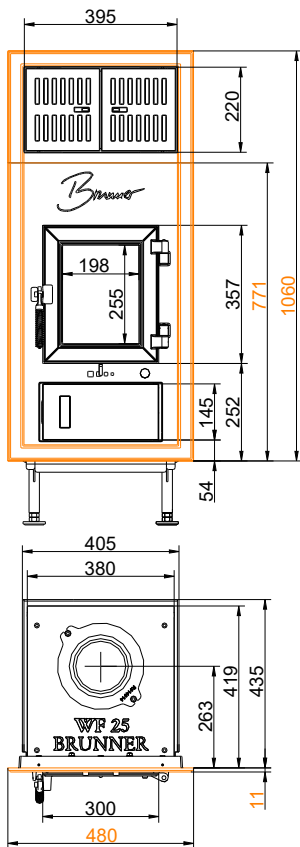

... cast iron front plate 1060 x 480

Dimension sheets - WF_R 25

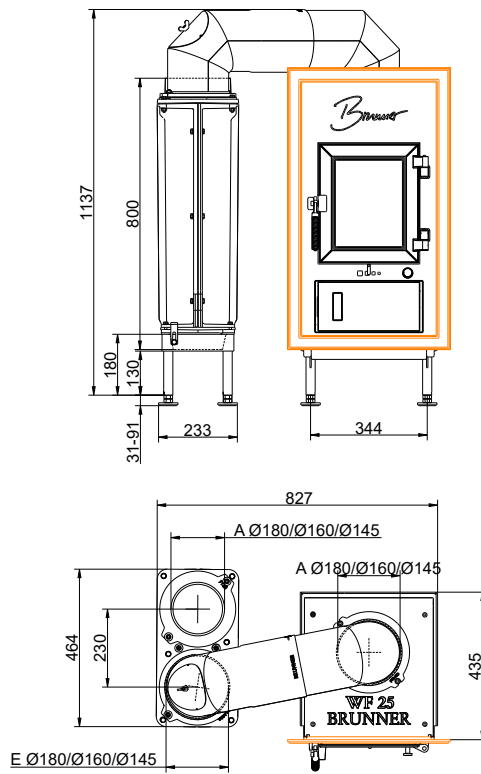

... with GNF 8 at the side

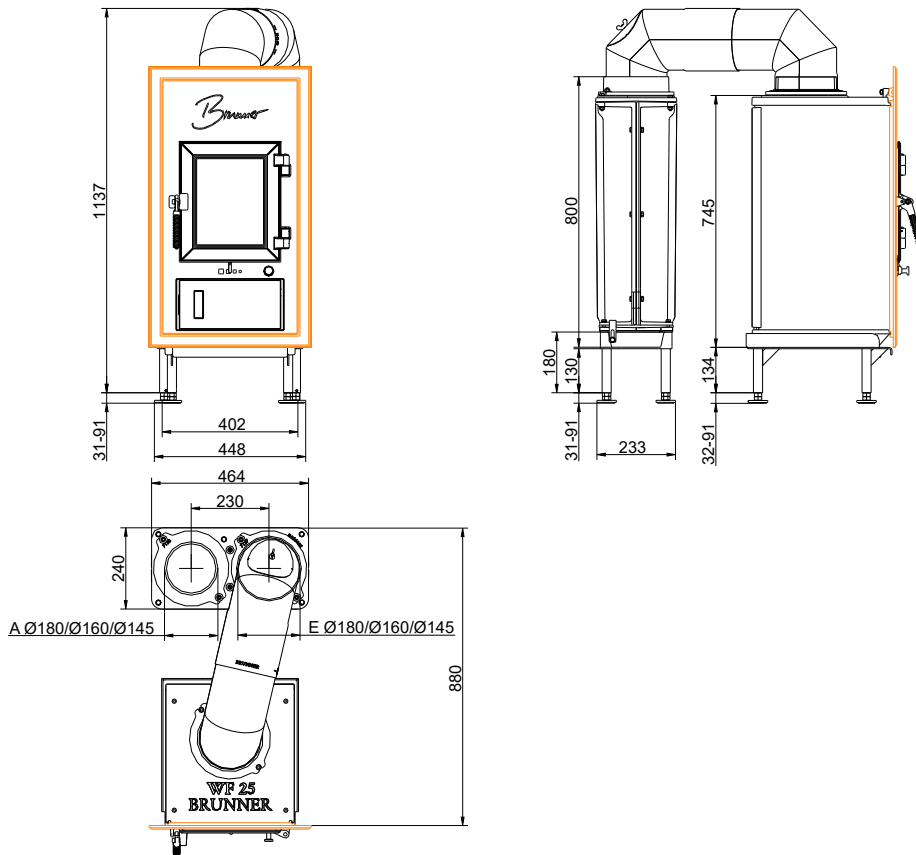

... with GNF 8 behind

Dimension sheets - WF_R 25

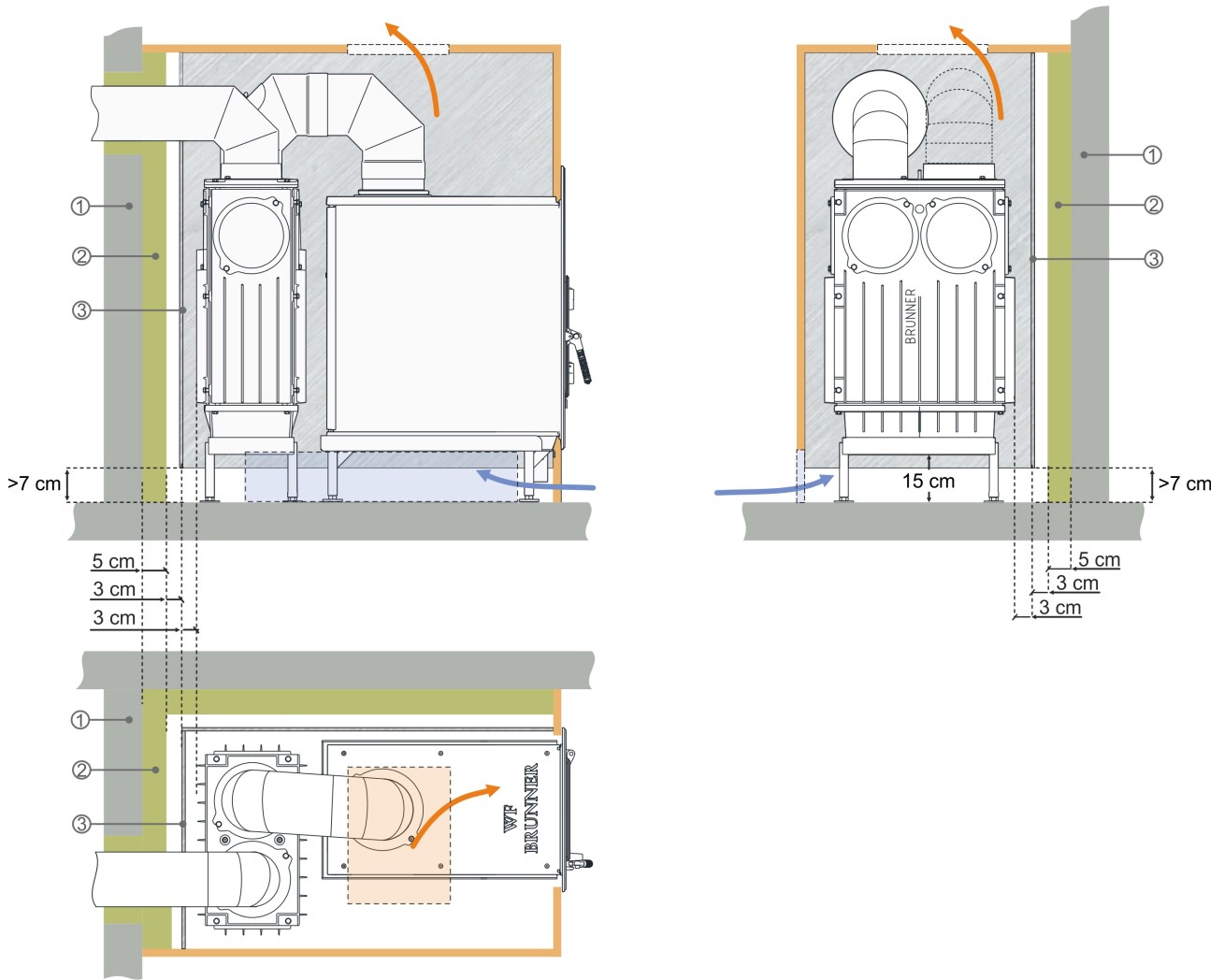

Alternative Wärmedämmung mit Hitzeschutzblech^{x)} vor Dämmschicht ^{xx)}.
1 Anbauwand (nicht brennbar), 2 Promasil 950KS, 3 Hitzeschutzblech feuerverzinkt (nicht schwarz).

^{x)} Hitzeschutzblech (kein schwarzes Blech!) wird bauseits über Abstandshalter zur Dämmschicht befestigt-

^{xx)} Werte ermittelt mit prüftechnisch erfassten Luftquerschnitten; Ofenhülle wärmeabgebend ausgeführt.

We suggest for CAD planning Palette CAD. Permanent updated drawings: www.brunner.de

Frames/ flue gas outlet connection/ combustion air supply connection/ front variants/ support bearing are marked in color.

Planning and installation - WF_R 25

Tested according to		EN 13229 W	Lignite EN 13229
Values measured at		Rated power ¹⁾	Rated power ¹⁾
Suitable for all construction types according to rules		OK	OK
Data for functional demonstration			
Rated heat power	kW	6	6
Fire wood volume	kg/h	2	1.4
Combustion performance	kW	8	8
Flue gas mass flow	g/s	6	6
Outlet temperature (before reheating surface)	°C	460	425
Flue gas temperature after:			
1 x adjoining cast iron radiator (GNF 8)	°C	210	200
3,6 m ceramic accumulator ²⁾	°C	180	170
2,3 m accumulation stones (MSS) ²⁾	°C	180	170
Necessary supply pressure	Pa	12	12
Combustion air consumption	m ³ /h	18.5	15.5
Combustion air connection Ø	mm	125	125
Heating gas temperature (before the hood/dome variant)			
insert flue outlet nozzle	°C	430	520
Heat distribution			
Insert / reheating surface	%	50 / 40	50 / 40
Glass pane (single / double)	%	10 / -	10 / -
Cross-section of gratings ³⁾			
Convection air	cm ²	400 / 200 / 400	400 / 200 / 400
Supply air	cm ²	400 / 200 / 400	400 / 200 / 400
Minimal distances of the fireplace			
to cladding, insulation layer	cm	8	8
to mounting floor	cm	15	15
Thermal insulation without / with air gratings ⁴⁾			
Mounting wall	cm	14 / 12	14 / 12
Floor	cm	0	0
Ceiling	cm	22 / 17	22 / 17
Brick lining for combustible wall	cm	10	10
Weight			
Fireplace / combustion chamber	kg	133 / 30,5 / 163,5	
Meets requirement/limit values for:			
Germany/ Austria / Switzerland / Norway		1.BImSchV (Stufe 2) / 15a BVG (2015) / LRV / -	

1) Indications to "Rated power" determined with metallic reheating surface and Double elbow

2) Approximate value

3) for fireplace inserts / flue gas pipe / metallic reheating surface

4) Values determined with air cross-sections evaluated by testing; stove cladding is heat emitting.