

FIREPLACE INSERTS FROM BRUNNER



Architektur-Tunnel 53/166

State: 2023-08-21



BRUNNER[®]
made in germany.

Dimension sheets - Architektur-Tunnel 53/166

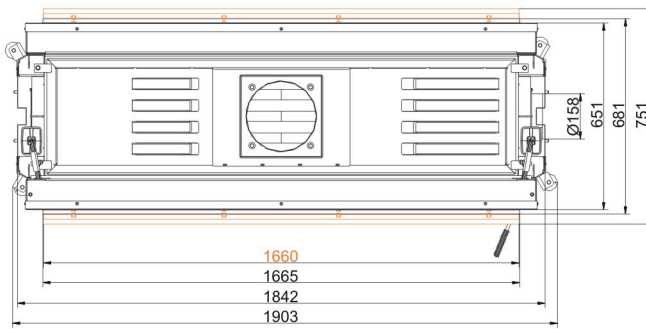
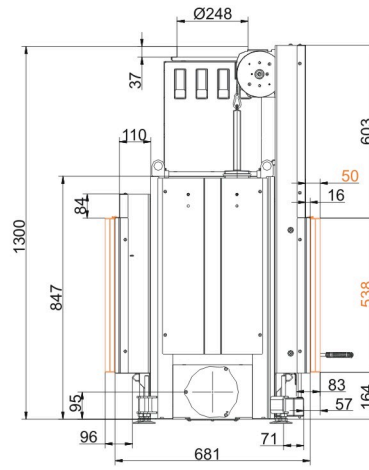
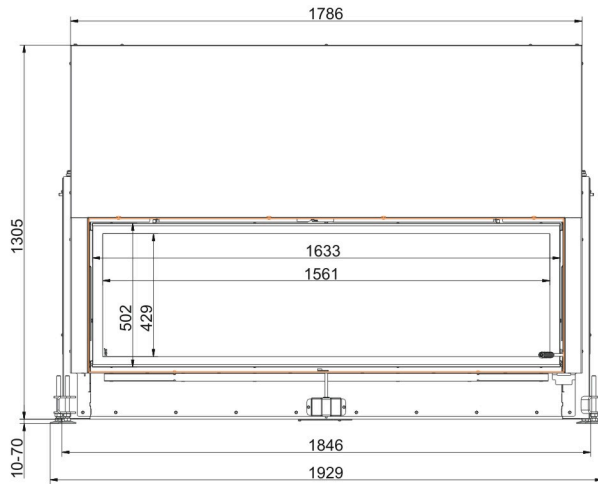

... /tilting door with mounting frame 50 mm

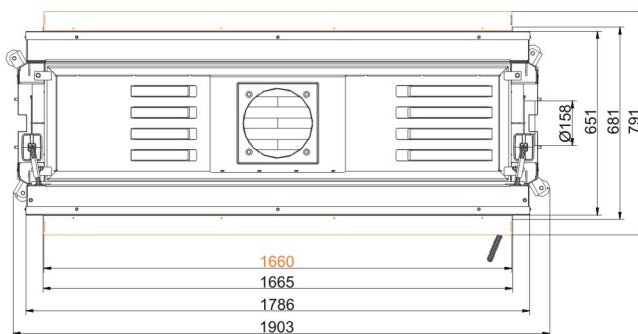
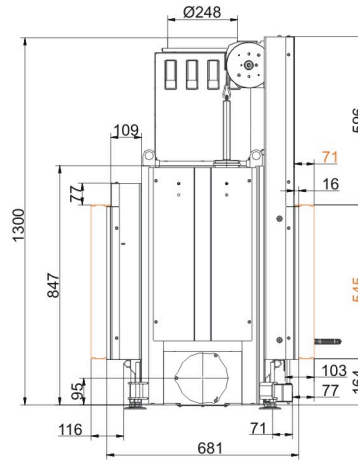
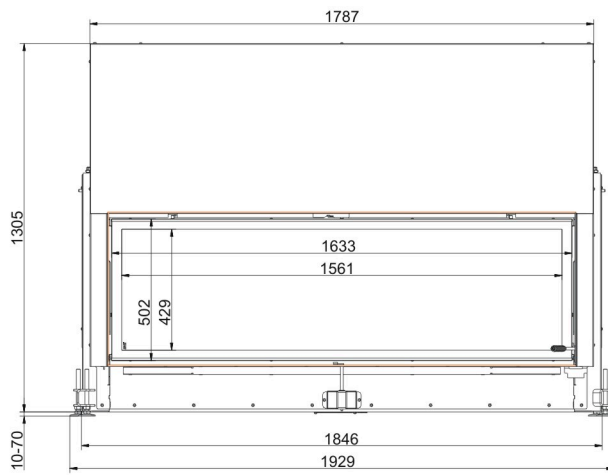

... /tilting door with mounting frame 70 mm

Dimension sheets - Architektur-Tunnel 53/166

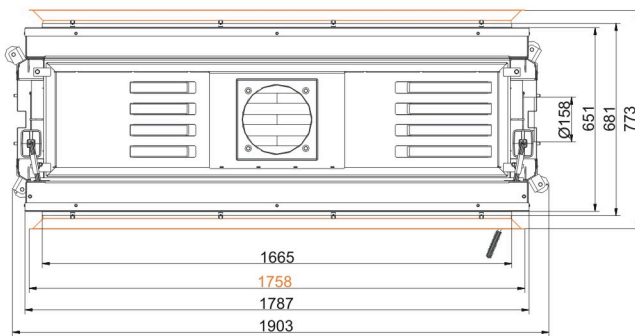
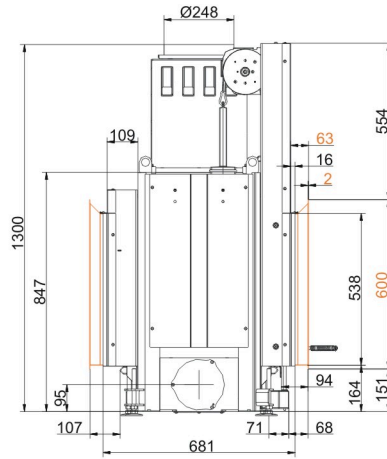
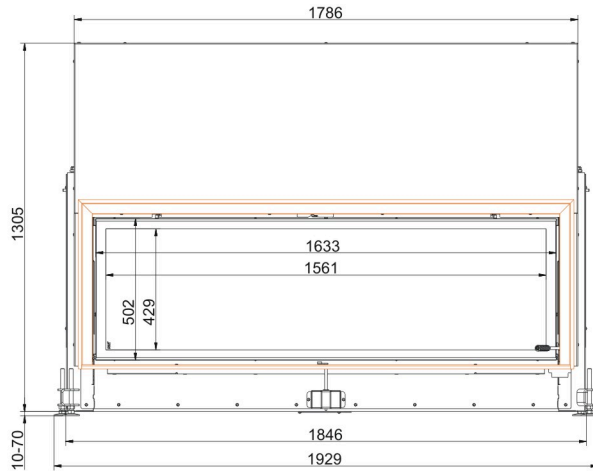

... /tilting door with door frame

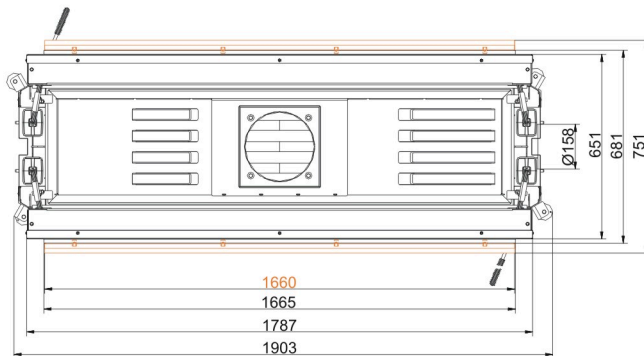
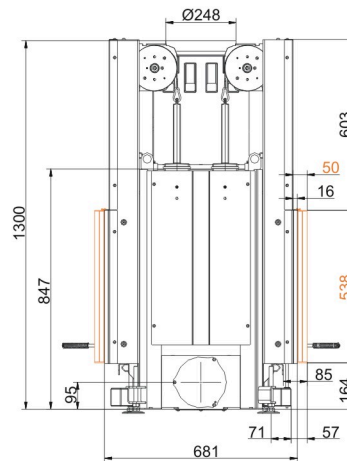
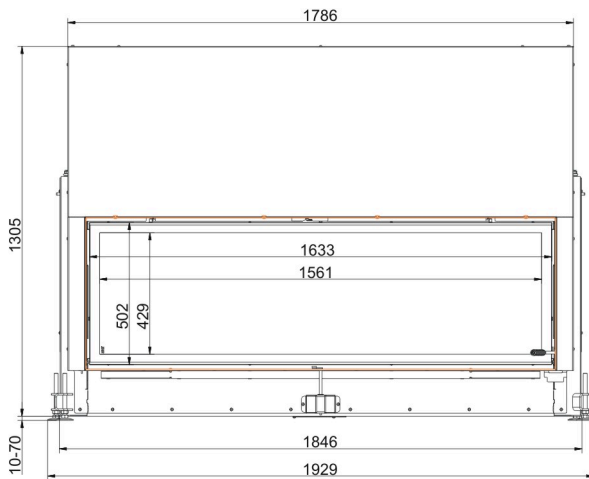

... with mounting frame 50 mm

Dimension sheets - Architektur-Tunnel 53/166

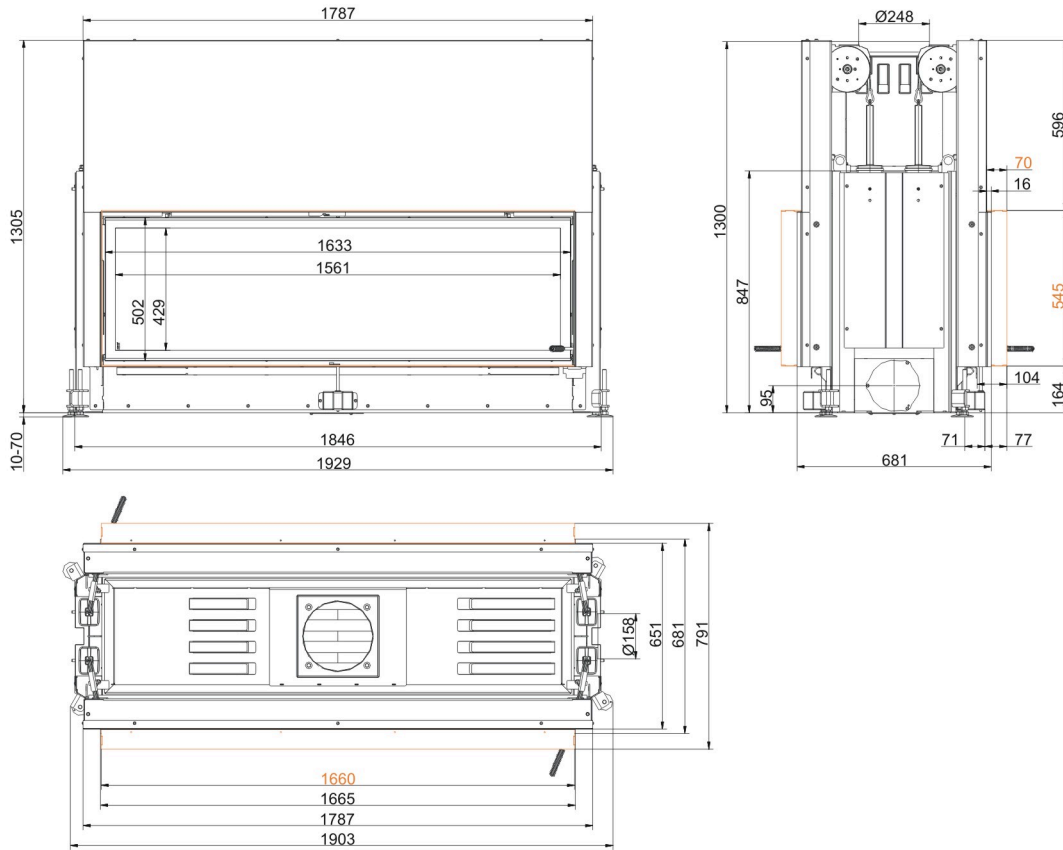

... with mounting frame 70 mm

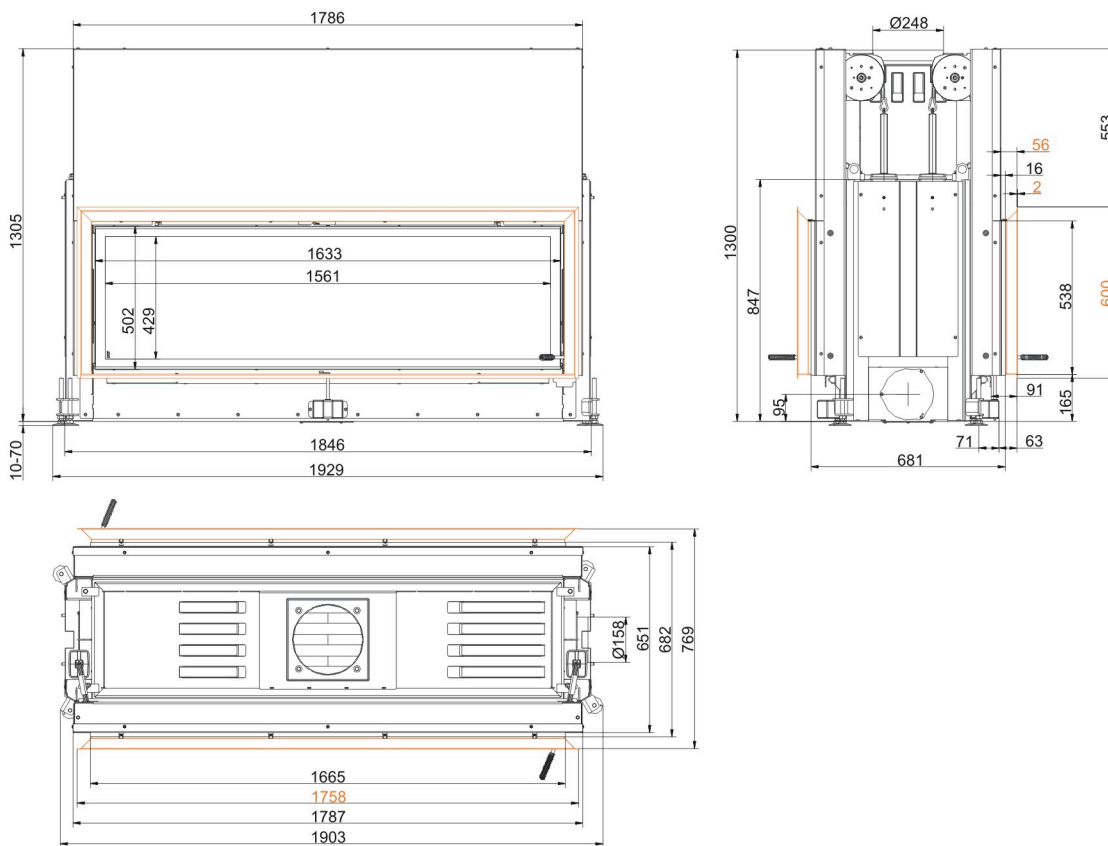

... with door frame

We suggest for CAD planning Palette CAD. Permanent updated drawings: www.brunner.de
 Frames/ flue gas outlet connection/ combustion air supply connection/ front variants/ support bearing are marked in color.

Planning and installation - Architektur-Tunnel 53/166

Tested according to		EN 13229 W
Values measured at		Rated power ¹⁾
Suitable for all construction types according to rules		OK
Data for functional demonstration		
Rated heat power	kW	17
Fire wood volume	kg/h	4.3
Combustion performance	kW	21
Flue gas mass flow	g/s	14.5
Flue gas temperature after:		
metallic hot air hood	°C	225
Necessary supply pressure	Pa	13
Combustion air consumption	m ³ /h	50
Combustion air connection Ø	mm	160
Heat distribution		
Insert / reheating surface	%	50 / -
Glass pane (single / double)	%	50 / -
Cross-section of gratings ²⁾		
Convection air	cm ²	900 / 100 / -
Supply air	cm ²	900 / 100 / -
Minimal oven surface for closed construction type		
Heat dissipating surface	m ²	5.5
Minimal distances of the fireplace		
to cladding, insulation layer	cm	6
to mounting floor	cm	2
Thermal insulation without / with air gratings ³⁾		
Mounting wall	cm	16 / 12
Floor	cm	4 / 2
Ceiling	cm	25 / 18
Brick lining for combustible wall	cm	10
Weight		
Fireplace / combustion chamber	kg	436 / 99
Meets requirement/limit values for:		
Germany/ Austria / Switzerland / Norway		1.BImSchV (Stufe 2) / 15a BvG (2015) / LRV / -

1) Indications to "Rated power" determined with metallic reheating surface

2) for fireplace inserts / flue gas pipe / metallic reheating surface

3) Values determined with upper air cross-sections; stove cladding is heat emitting.